

Catalog No. CKR-30

REPLACEMENT PARTS MANUAL



10hp No. 2 — 15hp No. 3

MODEL CK

PLAIN — UNIVERSAL — VERTICAL
MILLING MACHINES

with standard
directional
table control

with mono-lever and
automatic cycle
table control



KEARNEY & TRECKER CORPORATION

MILWAUKEE 14, WISCONSIN, U.S.A.

Catalog No. CKR-30

REPLACEMENT PARTS MANUAL

For 10hp No. 2 and 15hp No. 3

MODEL CK
Plain, Universal and Vertical



Milling Machines

with mono-lever and
automatic cycle
table control

with standard
directional
control

One copy of this manual is furnished with each
new machine. Additional copies may be obtained
by writing direct to Kearney & Trecker Corporation.

Price: \$3.00

Copyright, 1951

**Kearney & Trecker
Corporation**

Milwaukee 14, Wisconsin

FOREWORD

This is a replacement parts manual for the 10hp No. 2 and the 15hp No. 3 Model CK Plain, Universal and Vertical Kearney & Trecker milling machines. In the purchase of these machine tools you possess an absolute guarantee of precision built equipment - designed and manufactured so as to assure the greatest measure of long life performance. There remains, however, still another responsibility - that of providing prompt service for replacement parts and general maintenance resulting from natural wear or accidental damage to the machine - to keep them in sound operating condition. This manual will help you do that quickly.

About the manual itself; every effort has been made to make this book as clear and concise as is practical to avoid delay and misunderstanding in ordering parts. The various assemblies are arranged in a natural sequence and are indexed visually on pages 4 and 5. (Figs. 3 and 4)

Instructions noted in the following pages must be followed carefully. In several instances it will be observed that certain parts are mated at the home factory. Such parts cannot be replaced individually and must be sent out in pairs or sets.

Kearney & Trecker maintains, insofar as possible, a complete record, based on machine serial number, of every machine built. To insure prompt and efficient service it is imperative, therefore, to include the machine size, model and serial number with every inquiry or order. This information will be found stamped in the lower border of the trademark located on the left side of the column.

It is our intention to continually improve the service you receive from Kearney & Trecker milling machines and make the parts replacement problem a simple procedure. By following the instructions for identifying and ordering parts, given on the next page, you will be assured of prompt service.

KEARNEY & TRECKER
Corporation
Milwaukee 14, Wisconsin
U. S. A.

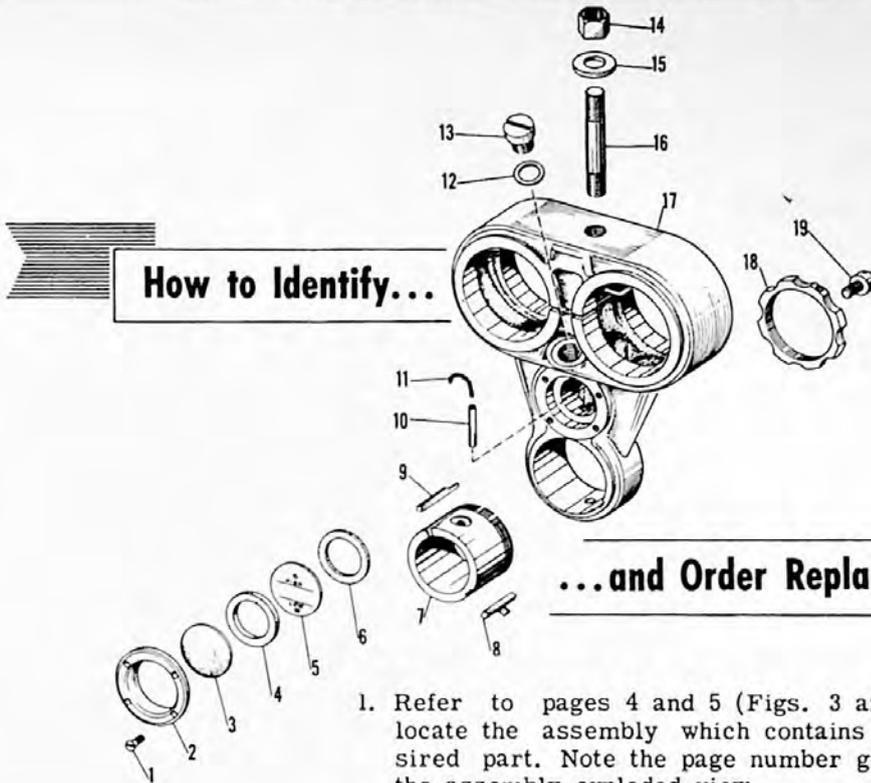

How to Identify...

...and Order Replacement Parts

1. Refer to pages 4 and 5 (Figs. 3 and 4) to locate the assembly which contains the desired part. Note the page number given for the assembly exploded view.
2. Locate the desired part and its item number in the assembly exploded view. For convenience and clearness in showing parts on some large units, it was necessary to remove them from the proper location in relation to the main casting. Such assemblies are indicated by a letter in a circle A, B, C, etc. A brief study of the exploded view will show where such sub-assemblies properly belong.
3. In the parts list on the facing page, find the corresponding item number to determine the part name, description and code number.
4. Send the part name, description, the code number and the SIZE, MODEL and SERIAL NUMBER OF THE MACHINE (stamped in the lower border of the trademark located on the left side of the column) to the Service Department, Kearney & Trecker Corporation, Milwaukee 14, Wisconsin, U.S.A.
5. For service by telephone, call Greenfield 6-8300, and give the information in paragraph 4 above.

Important

MODEL CK
10 hp No. 2 — 15 hp No. 3
PLAIN STYLE
with standard
directional
table control ▶

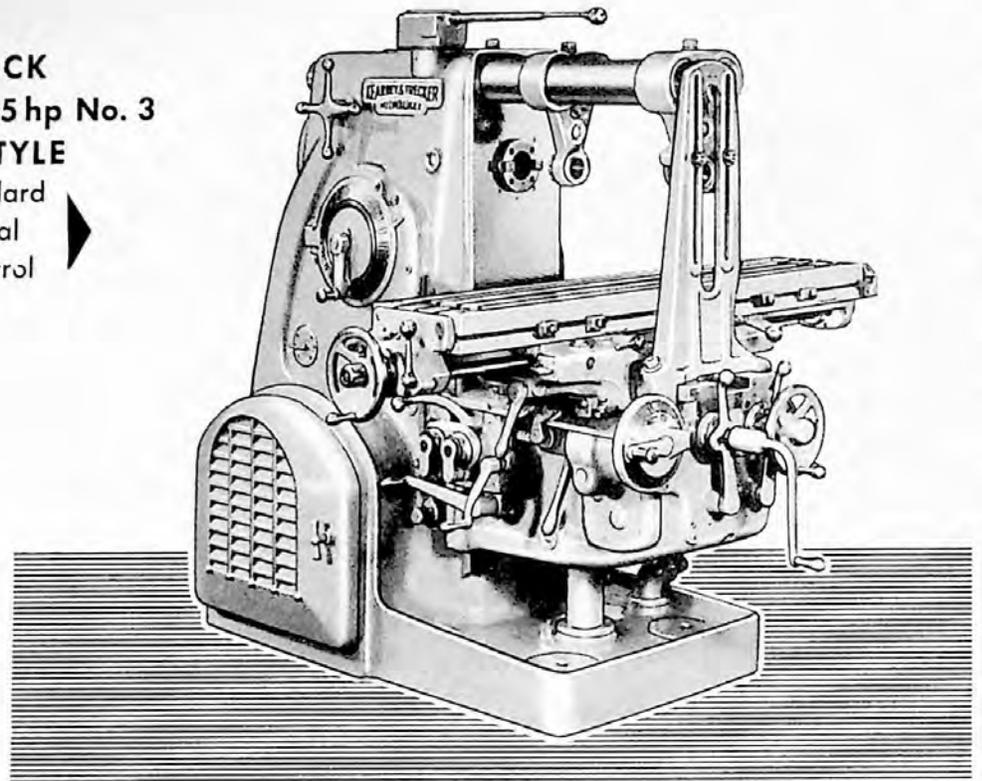

MODEL CK
10 hp No. 2 — 15 hp No. 3
UNIVERSAL STYLE
with standard
directional
table control ◀

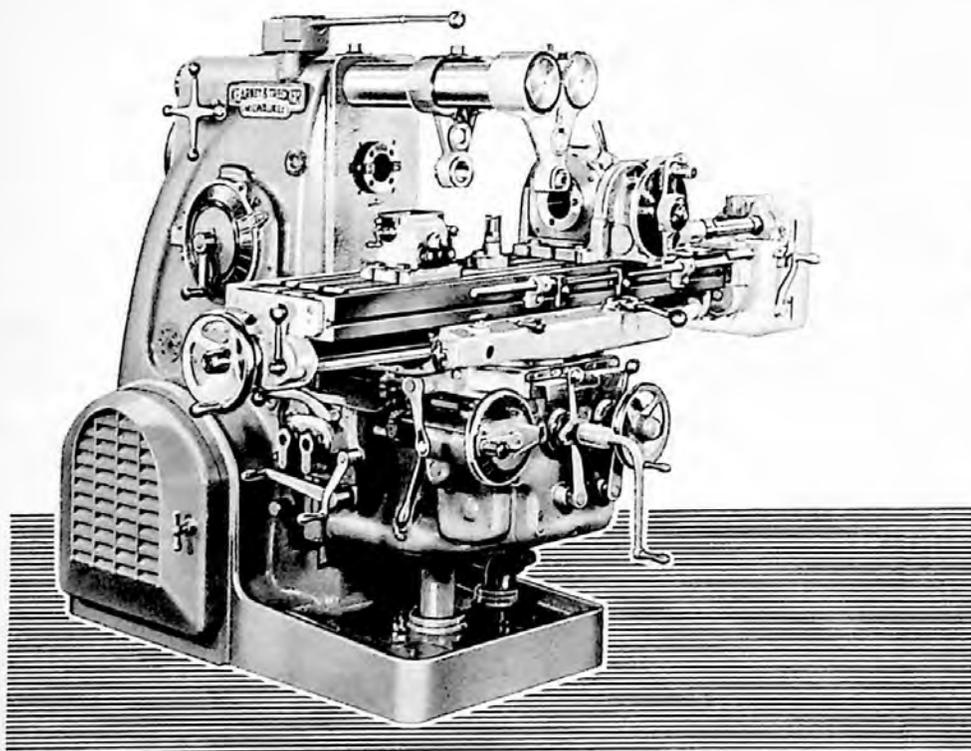
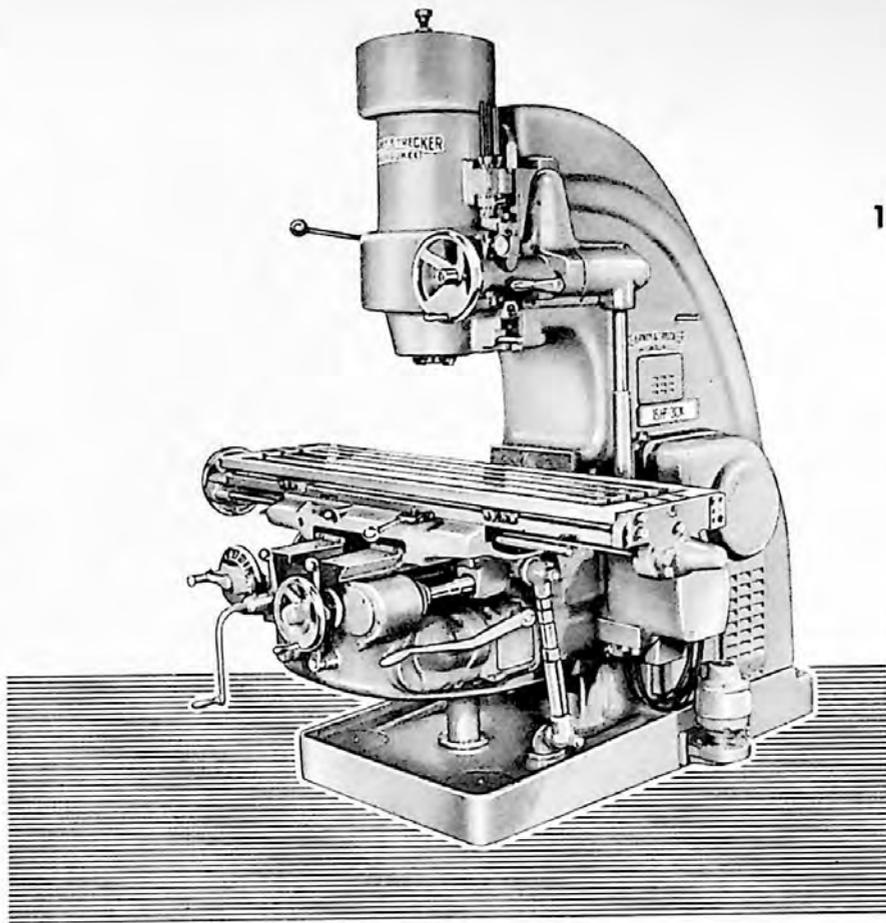

FIGURE 1



MODEL CK
10 hp No. 2 — 15 hp No. 3

VERTICAL STYLE

with standard
directional
table control

MODEL CK
10 hp No. 2 — 15 hp No. 3

VERTICAL STYLE

with mono-lever and
automatic cycle
table control

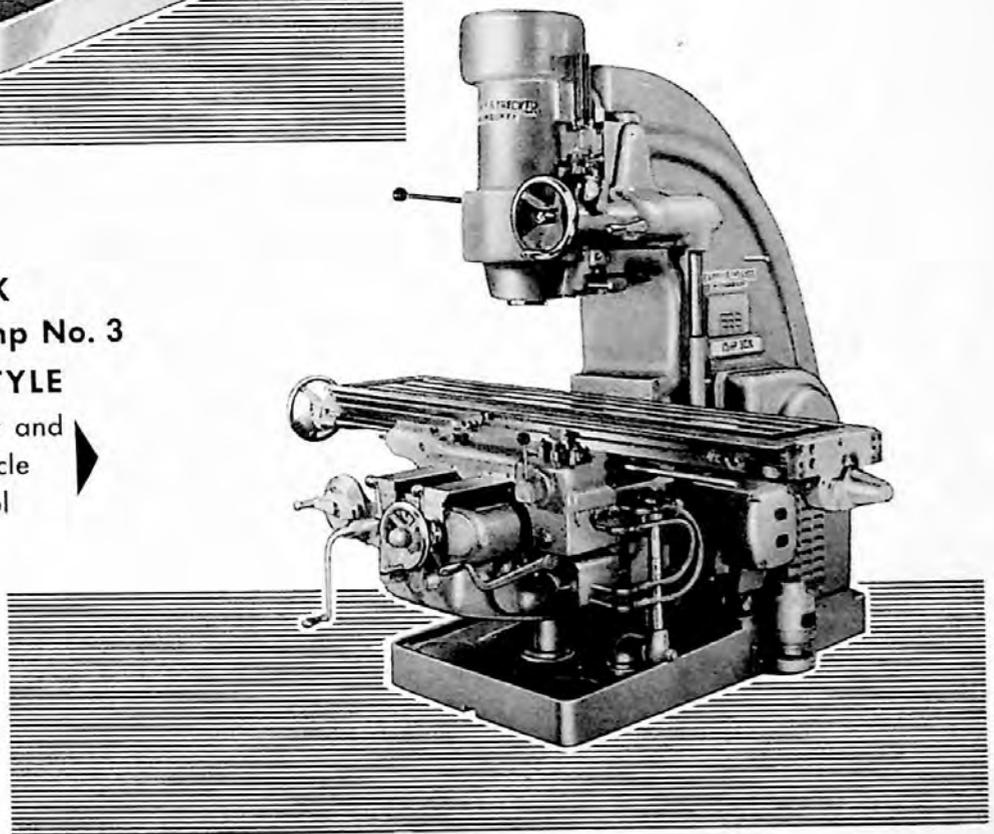

FIGURE 2

Replacement Parts Manual

10 hp No. 2 and 15 hp No. 3 Model CK

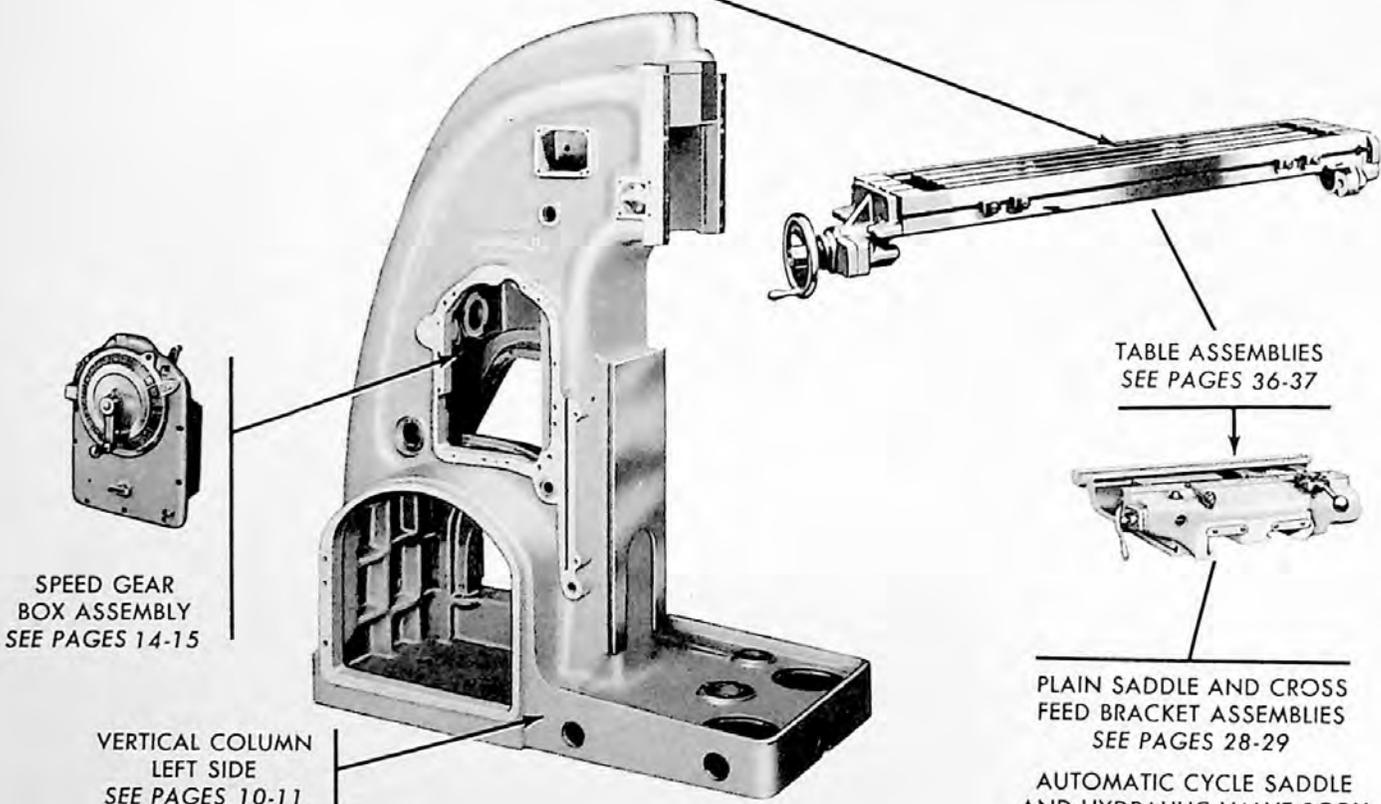
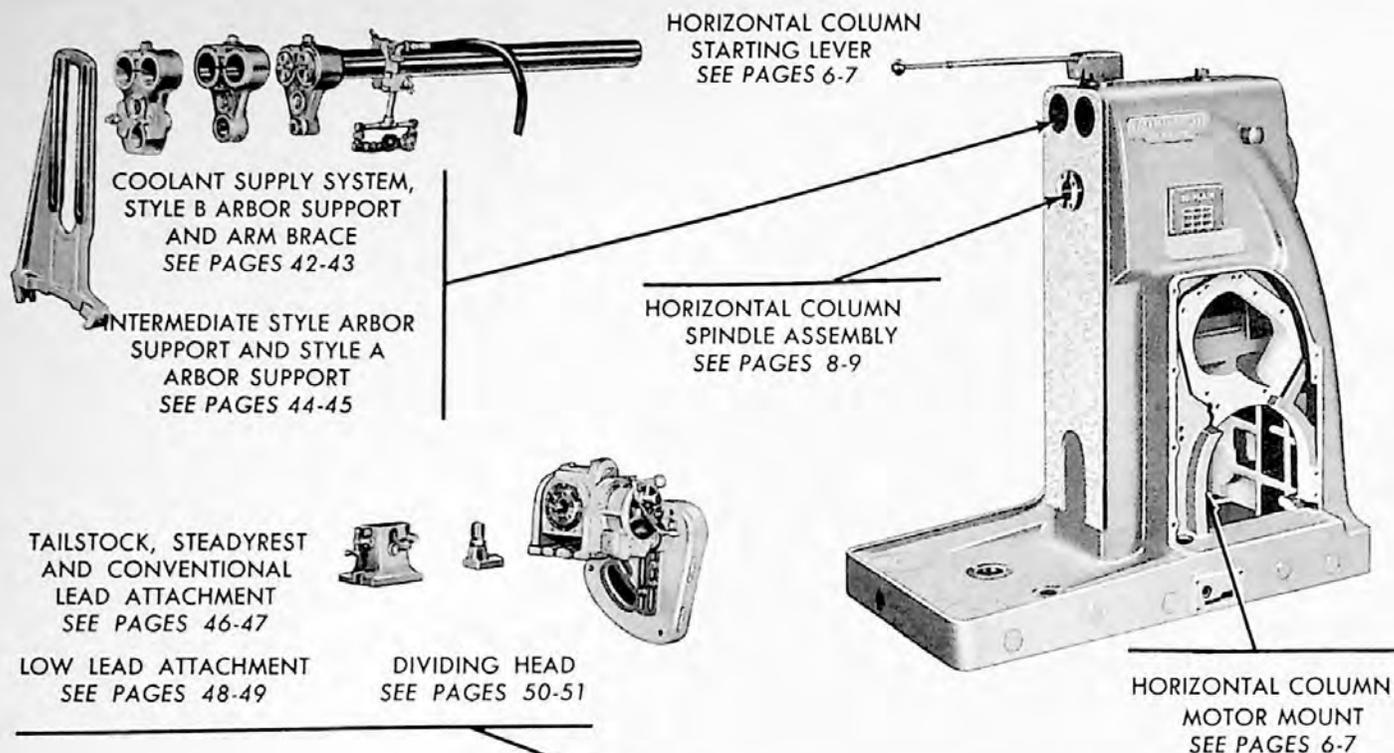

FIGURE 3



Replacement Parts Manual

Milling Machines—Plain, Universal and Vertical

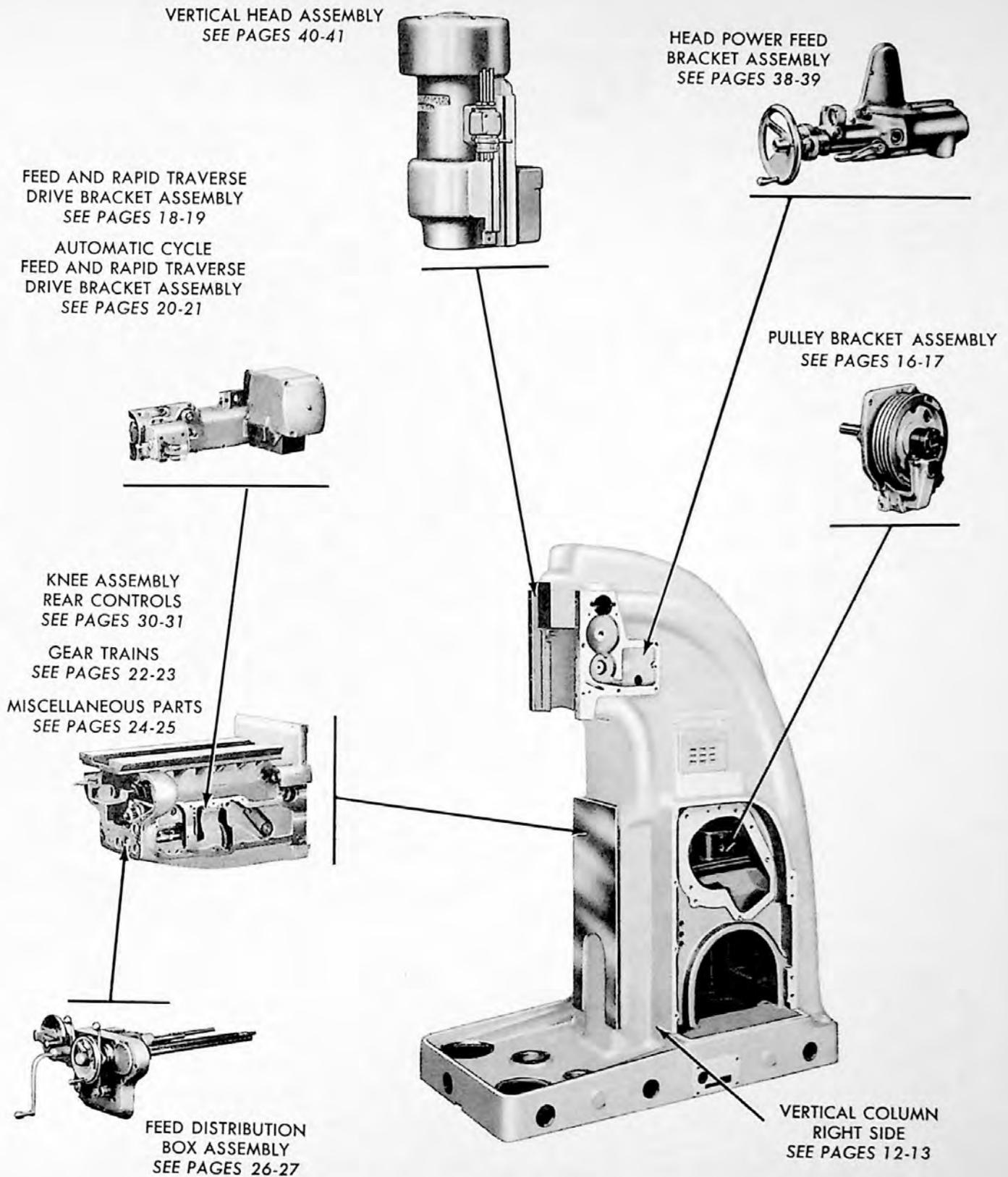

FIGURE 4

BUILDERS OF PRECISION AND PRODUCTION



MACHINE TOOLS FOR MILLING AND BORING



WHEN ORDERING PARTS
REPORT SERIAL NUMBER
SHOWN ON THIS PLATE

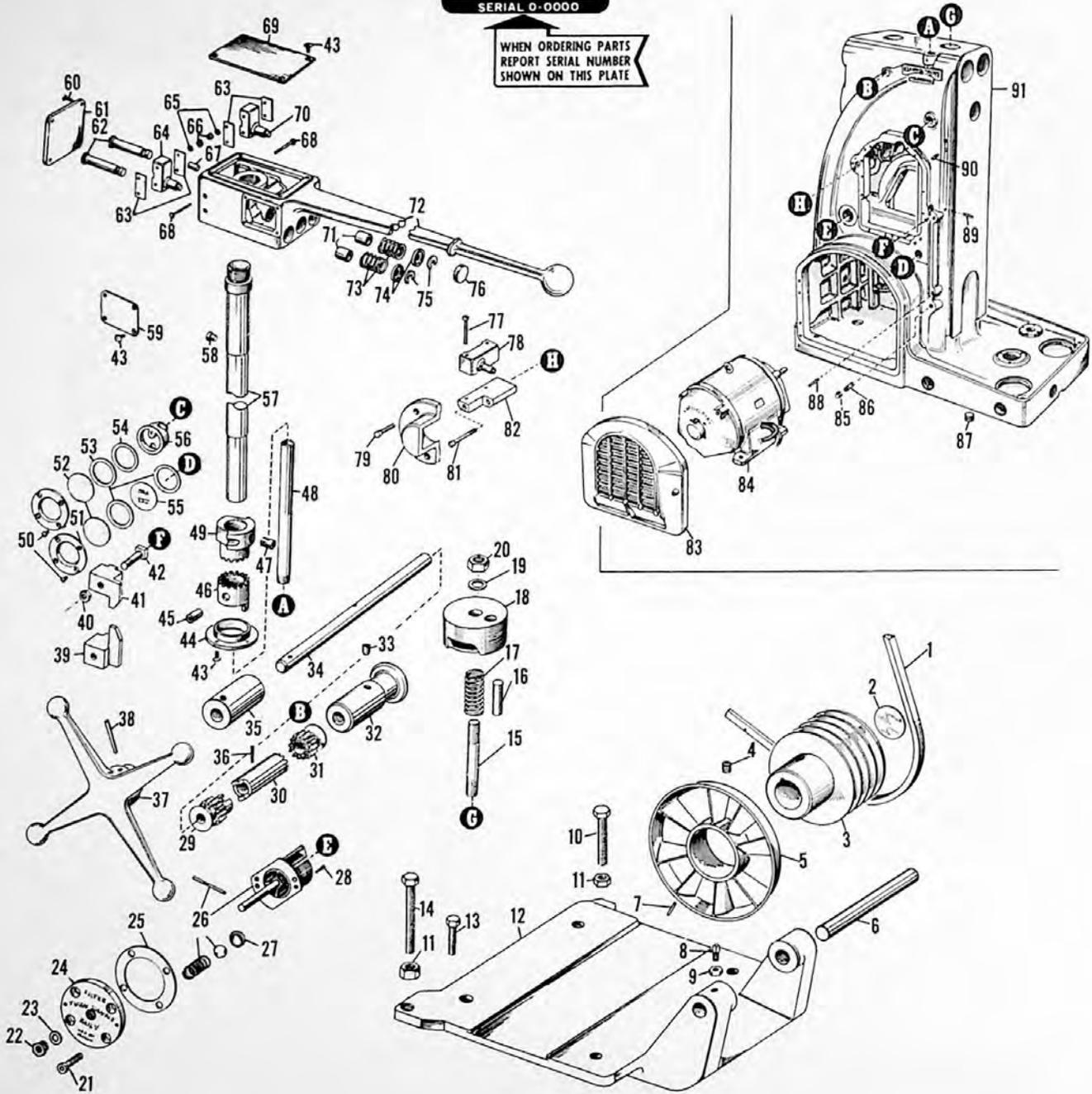

FIG. 5 - HORIZONTAL COLUMN, STARTING LEVER AND MOTOR MOUNT

Replacement Parts Manual

Milling Machines—Plain, Universal and Vertical

Fig. 5 - Horizontal Column, Starting Lever and Motor Mount

Item No.	Part Name and Description	Code Nos.		Qty.	Item No.	Part Name and Description	Code Nos.		Qty.
		2CK	3CK				2CK	3CK	
1	V-Belt (Give motor name plate data)	**2CK-A1	3CK-A1***	3	51	Oil sight gauge	2CK-A51	3CK-A51	1
2	Expansion plug, 2" diam	2CK-A2		1	52	Oil gauge glass	2CK-A52	3CK-A52	2
2	Expansion plug, 2-1/8" diam		3CK-A2	1	53	Oil gauge washer	2CK-A53	3CK-A53	3
3	Motor sheave (Give motor name plate data)	**2CK-A3	3CK-A3	1	54	Oil gauge washer	2CK-A54	3CK-A54	1
4	Socket set screw, flat pt. 1/2 x 1"	2CK-A4		2	55	Oil gauge plate	2CK-A55	3CK-A55	1
4	Socket set screw, flat pt. 1/2 x 1-1/4"		3CK-A4	2	56	Sight oil flow gauge	2CK-A56	3CK-A56	1
5	Motor fan	2CK-A5	3CK-A5	1	57	Starting lever shaft	2CK-A57	3CK-A57	1
6	Motor base support pin	2CK-A6	3CK-A6	1	58	Starting lever stop pin	2CK-A58	3CK-A58	1
7	Acme Blue Label dowel, 3/8 x 7/8"	2CK-A7	3CK-A7	1	59	Starting lever cover	2CK-A59	3CK-A59	1
8	Sq hd cup pt screw, 3/8 x 1-1/4"	2CK-A8	3CK-A8	1	60	Flat hd screw, 8-32 x 5/8"	2CK-A60	3CK-A60	4
9	Hex nut, 3/8-16"	2CK-A9	3CK-A9	1	61	Starting lever end cover	2CK-A61	3CK-A61	1
10	Hex hd cap screw, 3/4-10 x 4"	2CK-A10		1	62	Micro switch push rod	2CK-A62	3CK-A62	2
10	Hex hd cap screw, 3/4-10 x 5-5/8"		3CK-A10	1	63	Switch insulator plate	2CK-A63	3CK-A63	4
11	Hex nut, 3/4-10"	2CK-A11	3CK-A11	2	64	Allen-Bradley precision limit switch, Bulletin #802 type PBSJ20-15 (Normally open) K-103757	2CK-A64	3CK-A64	1
12	Motor base	2CK-A12	3CK-A12	1	65	Lockwasher, Shakeproof, #1106	2CK-A65	3CK-A65	4
13	Hex hd cap screw, 5/8-11 x 2-5/16"	2CK-A13	3CK-A13	4	66	Hex nut, 6-32	2CK-A66	3CK-A66	4
14	Hex hd cap screw, 3/4-10 x 5-5/8"	2CK-A14	3CK-A14	1	67	Acme Blue Label dowel, 5/16 x 5/8"	2CK-A67	3CK-A67	1
15	Stud	2CK-A15	3CK-A15	2	68	Switch support screw	2CK-A68	3CK-A68	4
16	Clamp block pin	2CK-A16	3CK-A16	2	69	Starting lever top cover	2CK-A69	3CK-A69	1
17	Spring	2CK-A17	3CK-A17	2	70	Allen-Bradley precision limit switch, Bulletin #802 type PBSJ20-15 (Double throw)	2CK-A70	3CK-A70	1
18	Overarm clamp	2CK-A18	3CK-A18	2	71	Starting lever stop sleeve	2CK-A71	3CK-A71	2
19	Washer, 3/4"	2CK-A19		2	72	Starting lever	2CK-A72	3CK-A72	1
19	Washer, 7/8"		3CK-A19	2	73	Spring	2CK-A73	3CK-A73	2
20	Hex nut, 3/4-10"	2CK-A20		2	74	Push rod stop washer	2CK-A74	3CK-A74	2
20	Hex nut, 7/8-9"		3CK-A20	2	75	Washer	2CK-A75	3CK-A75	2
21	Socket hd cap screw, 3/8 x 3/4"	2CK-A21	3CK-A21	4	76	Plug	2CK-A76	3CK-A76	3
22	Filter hd plug	2CK-A22	3CK-A22	1	77	Rd hd mach screw, 6-32 x 1-1/4"	2CK-A77	3CK-A77	2
23	Filter hd washer	2CK-A23	3CK-A23	1	78	Allen-Bradley precision limit switch, Bulletin #802 type PBSJ20-9	2CK-A78	3CK-A78	1
24	Filter hd	2CK-A24	3CK-A24	1	79	Fil hd screw, 5/16-18 x 5/8"	2CK-A79	3CK-A79	3
25	Filter hd gasket	2CK-A25	3CK-A25	1	80	Switch cover	2CK-A80	3CK-A80	1
26	100 Disc unit cartridge (Cuno B/P#B-1296)	2CK-A26	3CK-A26	1	81	Fil hd screw, 1/4-20 x 1-3/4"	2CK-A81	3CK-A81	2
27	Ball retainer	2CK-A27	3CK-A27	1	82	Switch bracket	2CK-A82	3CK-A82	1
28	Fil hd screw, 10-32 x 5/16"	2CK-A28	3CK-A28	2	83	Motor door	2CK-A83	3CK-A83	1
29	Overarm pinion (LH)	2CK-A29	3CK-A29	1		Door handle	2CK-A84	3CK-A84	1
30	Overarm clutch sleeve	2CK-A30	3CK-A30	1		Door latch	2CK-A85	3CK-A85	1
31	Overarm pinion (RH)	2CK-A31	3CK-A31	1		Sq hd cup pt screw, 1/4-20 x 5/8"	2CK-A86	3CK-A86	1
32	Overarm shaft bushing (RH)	2CK-A32	3CK-A32	1		Spacing washer	2CK-A87	3CK-A87	*
33	Dog pt sock set screw, 1/2 x 3/4"	2CK-A33	3CK-A33	2		Door hinge	2CK-A88	3CK-A88	2
34	Overarm pinion shaft	2CK-A34	3CK-A34	1		Hex hd cap screw, 3/8-16 x 13/16"	2CK-A89	3CK-A89	8
35	Overarm shaft bushing (LH)	2CK-A35	3CK-A35	1		Lockwasher, Shakeproof #1220	2CK-A90	3CK-A90	8
36	Pin	2CK-A36	3CK-A36	1	84	Motor (See motor name plate data)	2CK-A91	3CK-A91	1
37	Overarm handwheel	2CK-A37	3CK-A37	1	85	Pipe cap, 1"	2CK-A92	3CK-A92	1
38	Taper pin, #4 x 1-5/8"	2CK-A38		1	86	Nipple, 1 x 2"	2CK-A93	3CK-A93	1
38	Taper pin, #5 x 2-3/8"		3CK-A38	1	87	Pipe plug, 1-1/2" (Altered)	2CK-A94	3CK-A94	1
39	Elevating trip dog (LH)	2CK-A39	3CK-A39	1	88	Acme Blue Label dowel, 1/2 x 1-1/8"	2CK-A95	3CK-A95	2
40	Hex nut, 7/16-14"	2CK-A40	3CK-A40	1	89	Acme Blue Label dowel, 5/8 x 1-1/4"	2CK-A96		1
41	Elevating trip dog (RH)	2CK-A41	3CK-A41	1	89	Acme Blue Label dowel, 5/8 x 1-1/2"		3CK-A96	1
42	T-Bolt	2CK-A42	3CK-A42	2	90	Socket dog pt set screw, 3/8 x 1/2"	2CK-A97		1
43	Flat hd screw, 8-32 x 1/2"	2CK-A43	3CK-A43	12	90	Socket dog pt set screw, 3/8 x 1"		3CK-A97	1
44	Starting lever flange	2CK-A44	3CK-A44	1	91	Horizontal column	2CK-A98	3CK-A98	1
45	Dowel pin	2CK-A45	3CK-A45	1					
46	Starting lever positioning clutch	2CK-A46	3CK-A46	1					
47	Switch cam stop pin	2CK-A47	3CK-A47	1					
48	Starting lever stand pipe	2CK-A48	3CK-A48	1					
49	Switch push rod cam	2CK-A49	3CK-A49	1					
50	Oval hd screw, 10-32 x 15/32"	2CK-A50	3CK-A50	8					

**36012 (2CK, 50 cycle) (Dayton V-Belt #B63)

**36043 (2CK, 60 cycle) (Dayton V-Belt #B62)

**36009 (3CK, 50 cycle) (Dayton V-Belt #B67)

**36011 (3CK, 60 cycle) (Dayton V-Belt #B66)

***Four used on No. 3 machines

*Indicates as required

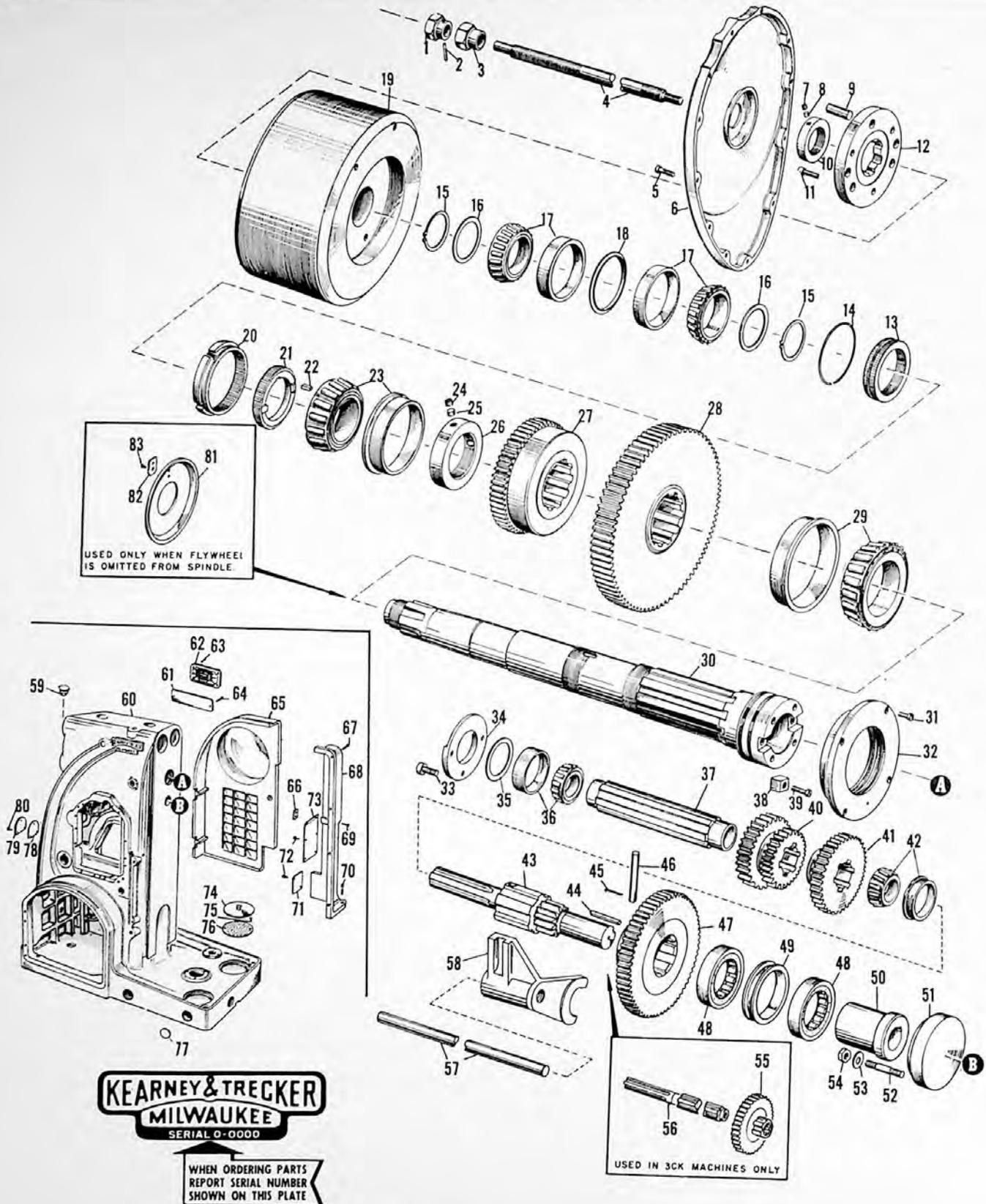

KEARNEY & TRECKER
MILWAUKEE
 SERIAL O-0000

WHEN ORDERING PARTS
 REPORT SERIAL NUMBER
 SHOWN ON THIS PLATE

USED IN 3CK MACHINES ONLY

FIG. 6 - HORIZONTAL COLUMN SPINDLE ASSEMBLY

Replacement Parts Manual

Milling Machines—Plain, Universal and Vertical

Fig. 6 - Horizontal Column Spindle Assembly

Item No.	Part Name and Description	Code Nos.		Qty.
		2CK	3CK	
1	Draw bolt hd	2CK-B1	3CK-B1	1
2	Taper pin, #4 x 1-1/4"	2CK-B2	3CK-B2	1
3	Draw bolt nut	2CK-B3	3CK-B3	1
4	Arbor draw-in bolt	2CK-B4	3CK-B4	1
5	Fil hd screw, 5/16-18 x 2"	2CK-B5		7
5	Fil hd screw, 5/16-18 x 7/8"	2CK-B6	3CK-B6	**3
6	Flywheel cover	2CK-B7	3CK-B7	1
7	Socket set screw, 3/8-24 x 3/8"	2CK-B8	3CK-B8	2
8	Collar nut shoe	2CK-B9	3CK-B9	2
9	Acme Blue Label dowel, 5/8 x 2-1/4"	2CK-B10	3CK-B10	3
10	Collar nut	2CK-B11	3CK-B11	1
11	Socket cap screw, 7/16 x 1-1/4"	2CK-B12	3CK-B12	3
12	Flywheel drive ring	2CK-B13	3CK-B13	1
13	Spindle brg drive collar nut	2CK-B14	3CK-B14	1
14	Snap ring	2CK-B15	3CK-B15	**2
15	Snap ring	2CK-B16	3CK-B16	**2
16	Spindle brg fitting washer	2CK-B17	3CK-B17	2
17	Timken brg, 33462-33275 (Spindle quality)	2CK-B18	3CK-B18	2
18	Spindle brg spacer	2CK-B19	3CK-B19	1
19	Flywheel	2CK-B20	3CK-B20	1
20	Spindle nut sleeve	2CK-B21	3CK-B21	1
21	Spindle bearing drive collar	2CK-B22	3CK-B22	1
22	Key	2CK-B23	3CK-B23	1
23	Timken brg, 563B-567W (Spindle quality)	2CK-B24		1
23	Timken brg, 742B-750W (Spindle quality)		3CK-B24	1
24	Set screw, 5/8-18 x 5/8"	2CK-B25	3CK-B25	2
25	Collar nut shoe	2CK-B26	3CK-B26	2
26	Collar nut	2CK-B27	3CK-B27	1
27	Small spindle gear	2CK-B28	3CK-B28	1
28	Large spindle gear	2CK-B29	3CK-B29	1
29	Timken brg, 742B-749 (Spindle quality)	2CK-B30		1
29	Timken brg, 77675B-77375		3CK-B30	1
30	Spindle	2CK-B31	3CK-B31	1
31	Fil hd screw, 5/16-18 x 7/8"	2CK-B32		4
31	Fil hd screw, 5/16 x 7/8"		3CK-B32	4
32	Spindle oil shield	2CK-B33	3CK-B33	1
33	Fil hd screw, 7/16-14 x 1-1/8"	2CK-B34	3CK-B34	3
34	Spindle drive shaft brg retainer	2CK-B35	3CK-B35	1
35	Brg spacer	2CK-B36	3CK-B36	1
36	Timken brg, 3320-3384	2CK-B37	3CK-B37	1
37	Primary speed change shaft	2CK-B38		1
38	Spindle drive key	2CK-B39	3CK-B39	2
39	Fil hd screw, 7/16-14 x 1-5/16"	2CK-B40	3CK-B40	2
40	Primary high speed sliding gear	2CK-B41	3CK-B41	1
41	Primary low speed sliding gear	2CK-B42	3CK-B42	1
42	Timken brg, 3320B-3384	2CK-B43	3CK-B43	1
43	Spindle drive pinion	2CK-B44		1

Item No.	Part Name and Description	Code Nos.		Qty.
		2CK	3CK	
44	Key	2CK-B45		1
45	Cotter pin, 1/8 x 7/8"	2CK-B46		2
46	Spindle drive gear retainer pin	2CK-B47		1
47	Spindle drive gear (Driver)	2CK-B48		1
48	Hyatt brg, 1310TS	2CK-B49	3CK-B49	2
49	Primary change shaft brg spacer	2CK-B50		1
50	Spindle drive pinion brg sleeve	2CK-B51	3CK-B51	1
51	Spindle drive pinion brg cover	2CK-B52	3CK-B52	1
52	Stud	2CK-B53	3CK-B53	2
53	Washer, 3/8"	2CK-B54	3CK-B54	2
54	Hex nut, 3/8-16"	2CK-B55	3CK-B55	2
55	Sliding spindle drive gear		3CK-B56	1
56	Spindle drive shaft		3CK-B57	1
57	Range shifter rod	2CK-B58	3CK-B58	1
58	Range change shifter fork	2CK-B59	3CK-B59	1
59	Gits oiler, #409	2CK-B60	3CK-B60	1
60	Horizontal column	2CK-B61	3CK-B61	1
61	Name plate	2CK-B62	3CK-B62	1
62	Column vent plate	2CK-B63	3CK-B63	1
63	Fil hd screw, 3/8-16 x 7/8"	2CK-B64	3CK-B64	5
64	Oval hd screw, 10-32 x 3/4"	2CK-B65	3CK-B65	2
65	Pulley door	2CK-B66	3CK-B66	1
	Door handle	2CK-B67	3CK-B67	1
	Door latch	2CK-B68	3CK-B68	1
	Sq hd cup pt screw, 1/4-20x5/8"	2CK-B69	3CK-B69	1
	Spacing washer	2CK-B70	3CK-B70	*
	Door hinge	2CK-B71	3CK-B71	2
	Hex hd cap screw, 3/8-16 x 13/16"	2CK-B72	3CK-B72	8
	Lockwasher, Shakeproof #1220	2CK-B73	3CK-B73	8
66	Door latch strip	2CK-B74	3CK-B74	1
67	Socket hd cap screw, 3/8 x 1"	2CK-B75		4
67	Socket hd cap screw, 1/2 x 1"		3CK-B75	4
68	Pulley door corner bracket	2CK-B76	3CK-B76	1
69	Socket hd cap screw, 5/16 x 5/8"	2CK-B77	3CK-B77	2
70	Socket hd cap screw, 1/2 x 1"	2CK-B78		1
70	Socket hd cap screw, 1/2 x 1-1/4"		3CK-B78	1
71	Junction box cover	2CK-B79	3CK-B79	1
72	Rd hd mach screw, 10-32 x 1/2"	2CK-B80	3CK-B80	8
73	Pump wiring chamber cover	2CK-B81	3CK-B81	1
74	Column drain screen cover	2CK-B82	3CK-B82	2
75	Flat hd mach screw, 10-32 x 3/8"	2CK-B83	3CK-B83	4
76	Column drain screen	2CK-B84	3CK-B84	2
77	Expansion plug, 2-3/4" diam	2CK-B85	3CK-B85	12
78	Paper gasket	2CK-B86	3CK-B86	1
79	Coolant cleanout cover	2CK-B87	3CK-B87	1
80	Fil hd screw, 3/8-16 x 13/16"	2CK-B88	3CK-B88	3
81	Oil slinger plate	2CK-B89	3CK-B89	1
82	Oil slinger key	2CK-B90	3CK-B90	1
83	Rivet, 3/16 x 3/8"	2CK-B91	3CK-B91	2

***Only one used on No. 3 machines

**Twelve used on No. 3 machines

* Indicates as required

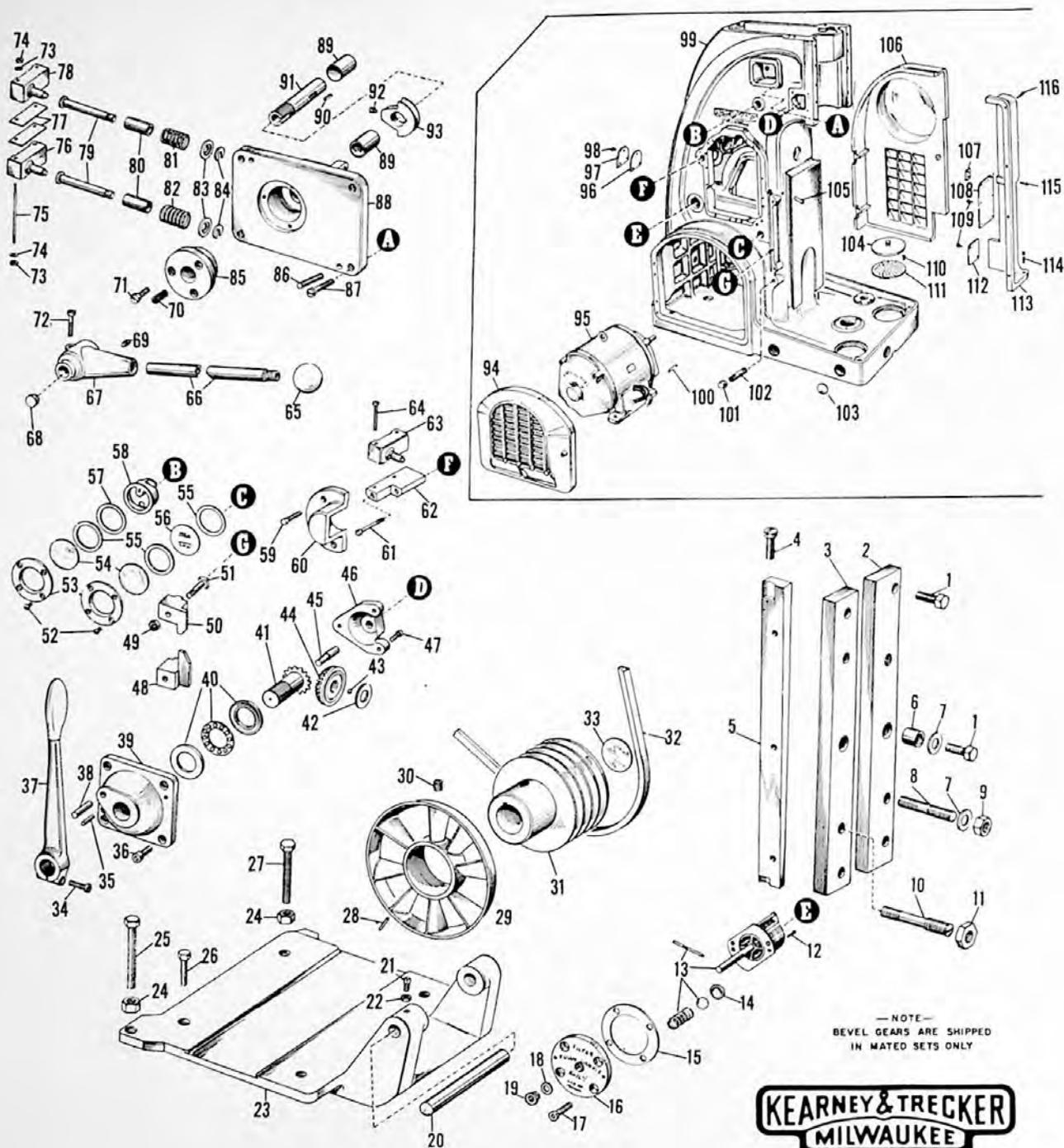

FIG. 7 - VERTICAL COLUMN LEFT SIDE

BUILDERS OF PRECISION AND PRODUCTION



MACHINE TOOLS FOR MILLING AND BORING

Replacement Parts Manual

Milling Machines—Plain, Universal and Vertical

Fig. 7 - Vertical Column Left Side

Item No.	Part Name and Description	Code Nos.		Qty.
		2CK	3CK	
1	Hex hd cap screw, 5/8-11 x 1-1/2"	2CK-C1	3CK-C1	6
2	Hd gib (RH)	2CK-C2	3CK-C2	1
3	Hd gib (LH)	2CK-C3	3CK-C3	1
4	Gib screw	2CK-C4	3CK-C4	2
5	Hd taper gib	2CK-C5	3CK-C5	1
6	Hd gib spacer	2CK-C6	3CK-C6	2
7	Washer, 5/8"	2CK-C7	3CK-C7	5
8	Stud	2CK-C8	3CK-C8	3
9	Hex nut, 5/8-11"	2CK-C9	3CK-C9	3
10	Hd clamp stud	2CK-C10	3CK-C10	1
11	Hex nut, 3/4-10"	2CK-C11	3CK-C11	1
12	Fil hd screw, 10-32 x 5/16"	2CK-C12	3CK-C12	2
13	100Disc unit cartridge (Cuno B/P #B-1296)	2CK-C13	3CK-C13	1
14	Ball retainer	2CK-C14	3CK-C14	1
15	Filter hd gasket	2CK-C15	3CK-C15	1
16	Filter hd	2CK-C16	3CK-C16	1
17	Sock hd cap screw, 3/8 x 3/4"	2CK-C17	3CK-C17	4
18	Filter hd washer	2CK-C18	3CK-C18	1
19	Filter hd plug	2CK-C19	3CK-C19	1
20	Motor base support pin	2CK-C20	3CK-C20	1
21	Sq hd cup pt screw, 3/8 x 1-1/4"	2CK-C21	3CK-C21	1
22	Hex nut, 3/8-16"	2CK-C22	3CK-C22	1
23	Motor base	2CK-C23	3CK-C23	1
24	Hex nut, 3/4-10"	2CK-C24	3CK-C24	2
25	Hex hd cap screw, 3/4-10 x 5-5/8"	2CK-C25	3CK-C25	1
26	Hex hd cap screw, 5/8-11 x 2-5/16"	2CK-C26	3CK-C26	4
27	Hex hd cap screw, 3/4-10 x 4"	2CK-C27		1
27	Hex hd cap screw, 3/4-10 x 5-5/8"		3CK-C27	1
28	Acme Blue Label dowel, 3/8 x 7/8"	2CK-C28	3CK-C28	1
29	Motor fan	2CK-C29	3CK-C29	1
30	Sock set screw, flat pt, 1/2 x 1"	2CK-C30		2
30	Sock set screw, flat pt, 1/2 x 1-1/4"		3CK-C30	2
31	Motor sheave (Give motor nameplate data)	2CK-C31	3CK-C31	1
32	V-Belt (Give motor name plate data)	2CK-C32	3CK-C32	**3
33	Expansion plug, 2" diam	2CK-C33		1
33	Expansion plug, 2-1/8" diam		3CK-C33	1
34	Sock hd cap screw, 5/16 x 1-1/8"	2CK-C34	3CK-C34	1
35	Acme Blue Label dowel, 1/4 x 3/4"	2CK-C35		2
35	Acme Blue Label dowel, 1/4 x 1"		3CK-C35	2
36	Sock hd cap screw, 3/8 x 3/4"	2CK-C36	3CK-C36	4
37	Hd clamp handle	2CK-C37	3CK-C37	1
38	Acme Blue Label dowel, 3/8 x 1"	2CK-C38		1
38	Acme Blue Label dowel, 3/8 x 1-1/2"		3CK-C38	1
39	Clamp pinion brg plate	2CK-C39	3CK-C39	1
40	Ball thrust brg	2CK-C40	3CK-C40	1
41	Hd clamp bevel pinion	2CK-C41	3CK-C41	1
42	Hd clamp bevel gear collar	2CK-C42	3CK-C42	1
43	Steel ball, 3/16" diam	2CK-C43	3CK-C43	19
44	Hd clamp bevel gear	2CK-C44	3CK-C44	1
45	Hd clamp pinion stud	2CK-C45	3CK-C45	1
46	Pinion stud support	2CK-C46	3CK-C46	1
47	Fil hd screw, 5/16-18 x 7/8"	2CK-C47		3
47	Fil hd screw, 5/16-18 x 3/4"		3CK-C47	3
48	Elevating trip dog (LH)	2CK-C48	3CK-C48	1
49	Hex nut, 7/16-14"	2CK-C49	3CK-C49	2
50	Elevating trip dog (RH)	2CK-C50	3CK-C50	1
51	T-Bolt	2CK-C51	3CK-C51	2
52	Oval hd screw, 10-32 x 15/32"	2CK-C52	3CK-C52	8
53	Oil sight gauge	2CK-C53	3CK-C53	2
54	Oil gauge glass	2CK-C54	3CK-C54	2
55	Oil gauge washer	2CK-C55	3CK-C55	3
56	Oil gauge plate	2CK-C56	3CK-C56	1
57	Oil gauge washer	2CK-C57	3CK-C57	1
58	Oil flow gauge	2CK-C58	3CK-C58	1
59	Fil hd screw, 5/16-18 x 5/8"	2CK-C59	3CK-C59	3
60	Switch cover	2CK-C60	3CK-C60	1
61	Fil hd screw, 1/4-20 x 1-3/4"	2CK-C61	3CK-C61	2
62	Switch bracket	2CK-C62	3CK-C62	1
63	Precision limit switch, Allen-Bradley Bulletin #802, Type PBSJ20-9	2CK-C63	3CK-C63	1
64	Rd hd mach screw, 6-32 x 1-1/4"	2CK-C64	3CK-C64	2

Item No.	Part Name and Description	Code Nos.		Qty.
		2CK	3CK	
65	Knob	2CK-C65	3CK-C65	1
66	Starting lever	2CK-C66	3CK-C66	1
67	Starting lever hub	2CK-C67	3CK-C67	1
68	Plug	2CK-C68	3CK-C68	1
69	Sock dog pt screw, (Altered)	2CK-C69	3CK-C69	1
70	Spring	2CK-C70	3CK-C70	2
71	Fil hd screw, 5/16-18 x 11/16"	2CK-C71	3CK-C71	3
72	Sock hd cap screw, 3/8 x 1-1/2"	2CK-C72	3CK-C72	1
73	Hex nut, 8-32	2CK-C73	3CK-C73	4
74	Lockwasher, Shakeproof #1106	2CK-C74	3CK-C74	4
75	Switch support screw	2CK-C75	3CK-C75	2
76	Precision limit switch, double throw, Allen-Bradley Bulletin #802 Type PBSJ20-15	2CK-C76	3CK-C76	1
77	Switch insulating spacer	2CK-C77	3CK-C77	2
78	Precision limit switch (normally open) Allen-Bradley PBSJ20-15	2CK-C78	3CK-C78	2
79	Switch push rod	2CK-C79	3CK-C79	2
80	Starting lever stop sleeve	2CK-C80	3CK-C80	2
81	Spring	2CK-C81	3CK-C81	1
82	Spring	2CK-C82	3CK-C82	1
83	Spring washer	2CK-C83	3CK-C83	2
84	"U" Washer	2CK-C84	3CK-C84	2
85	Rocker retainer	2CK-C85	3CK-C85	1
86	Acme Blue Label dowel, 5/16 x 1"	2CK-C86	3CK-C86	2
87	Fil hd screw, 3/8-16 x 7/8"	2CK-C87	3CK-C87	4
88	Starting lever bracket	2CK-C88	3CK-C88	1
89	Oilite brg, A-1110-1	2CK-C89	3CK-C89	2
90	Key	2CK-C90	3CK-C90	1
91	Starting lever shaft	2CK-C91	3CK-C91	1
92	Sock dog pt screw, 3/8-16 x 11/16"	2CK-C92	3CK-C92	1
93	Starting lever rocker	2CK-C93	3CK-C93	1
94	Motor door	2CK-C94	3CK-C94	1
	Door handle	2CK-C95	3CK-C95	1
	Door latch	2CK-C96	3CK-C96	1
	Sq hd cup pt screw, 1/4-20 x 5/8"	2CK-C97	3CK-C97	1
	Spacing washer	2CK-C98	3CK-C98	*
	Door hinge	2CK-C99	3CK-C99	2
	Hex hd cap screw, 3/8-16 x 13/16"	2CK-C100	3CK-C100	8
	Lockwasher, Shakeproof #1220	2CK-C101	3CK-C101	8
95	Motor, (See motor nameplate data)	2CK-C102		1
95	Motor, (See motor nameplate data)		3CK-C102	1
96	Paper gasket	2CK-C103	3CK-C103	1
97	Coolant cleanout cover	2CK-C104	3CK-C104	1
98	Fil hd screw, 3/8-16 x 13/16"	2CK-C105	3CK-C105	3
99	Vert column	2CK-C106	3CK-C106	1
100	Acme Blue Label dowel, 1/2 x 1-1/8"	2CK-C107	3CK-C107	2
101	Pipe cap	2CK-C108	3CK-C108	1
102	Nipple, 1 x 2"	2CK-C109	3CK-C109	1
103	Expansion plug, 2-3/4" diam	2CK-C110	3CK-C110	12
104	Column drain screen cover	2CK-C111	3CK-C111	2
105	Acme Blue Label dowel, 5/8 x 1-1/4"	2CK-C112	3CK-C112	1
106	Pulley door	2CK-C113	3CK-C113	1
	Door handle	2CK-C114	3CK-C114	1
	Door latch	2CK-C115	3CK-C115	1
	Sq hd cup pt screw, 1/4-20 x 5/8"	2CK-C116	3CK-C116	1
	Spacing washer	2CK-C117	3CK-C117	*
	Door hinge	2CK-C118	3CK-C118	2
	Hex hd cap screw, 3/8-16 x 13/16"	2CK-C119	3CK-C119	8
	Lockwasher, Shakeproof #1220	2CK-C120	3CK-C120	8
107	Door latch strip	2CK-C121	3CK-C121	1
108	Junction box cover	2CK-C122	3CK-C122	1
109	Rd hd mach screw, 10-32 x 1/2"	2CK-C123	3CK-C123	8
110	Flat hd mach screw, 10-32 x 3/8"	2CK-C124	3CK-C124	4
111	Column drain screen	2CK-C125	3CK-C125	2
112	Pump wiring chamber cover	2CK-C126	3CK-C126	1
113	Pulley door corner bracket	2CK-C127	3CK-C127	1
114	Sock hd cap screw, 1/2 x 1"	2CK-C128		1
114	Sock hd cap screw, 1/2 x 1-1/4"		3CK-C128	1
115	Sock hd cap screw, 5/16 x 5/8"	2CK-C129	3CK-C129	2
116	Sock hd cap screw, 3/8 x 1"	2CK-C130		4
116	Sock hd cap screw, 1/2 x 1"		3CK-C130	4

**Four used on No. 3 machines
*Indicates as required



WHEN ORDERING PARTS
REPORT SERIAL NUMBER
SHOWN ON THIS PLATE

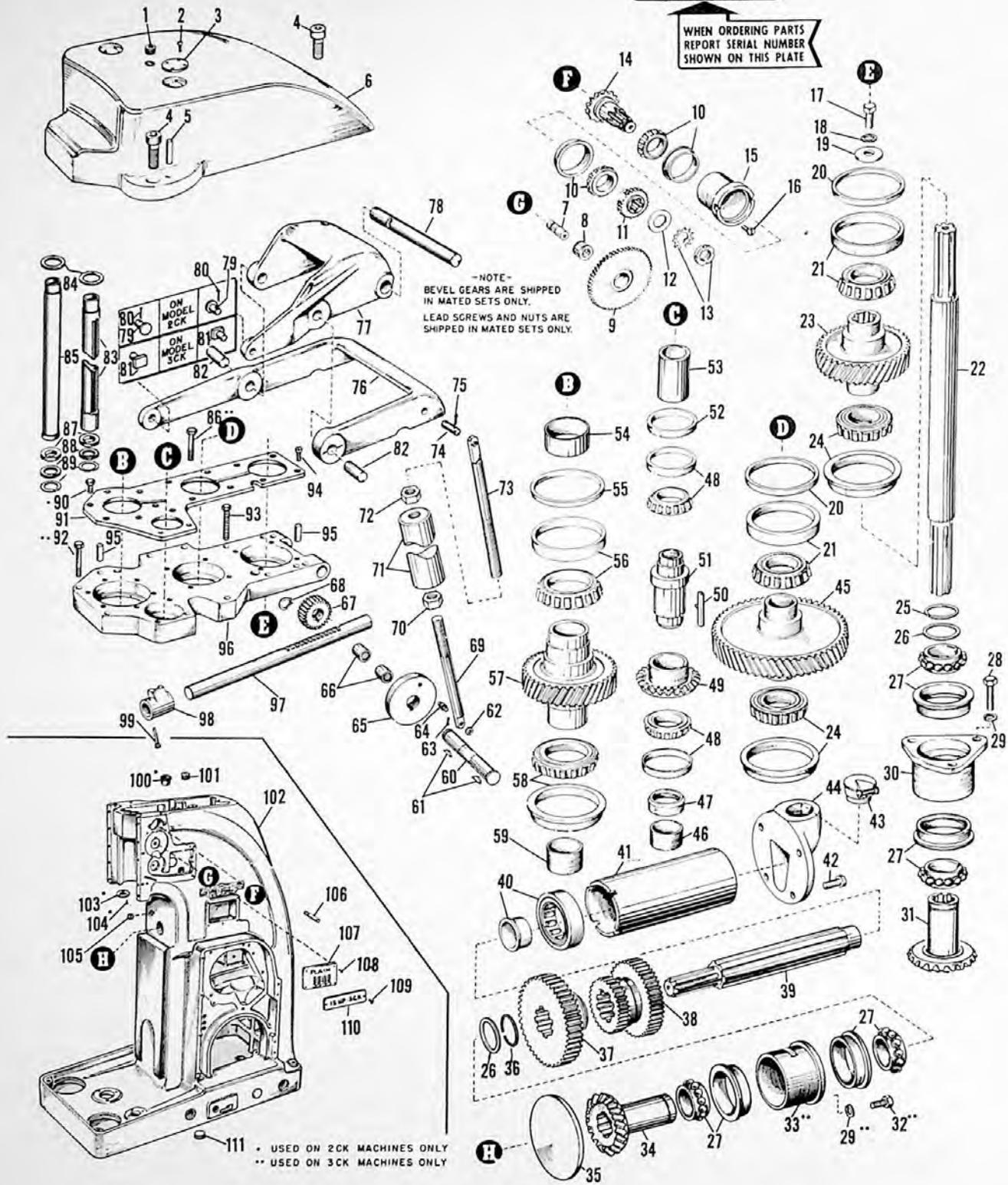

FIG. 8 - VERTICAL COLUMN RIGHT SIDE

Replacement Parts Manual

Milling Machines—Plain, Universal and Vertical

Fig. 8 - Vertical Column Right Side

Item No.	Part Name and Description	Code Nos.		Qty.
		2CK	3CK	
1	Socket hd pipe plug, 1/2"	2CK-D1		1
1	Pipe plug, 1/2"		3CK-D1	1
2	Flat hd mach screw, 10-32 x 1/2"	2CK-D2		6
2	Fil hd screw, 10-32 x 1/2"		3CK-D2	8
3	Sleeve adj cover	2CK-D3	3CK-D3	2
4	Socket hd cap screw, 3/4 x 1-1/2"	2CK-D4		3
4	Socket hd cap screw, 3/4 x 1-3/4"		3CK-D4	2
4	Socket hd cap screw, 3/4 x 2"		3CK-D5	1
5	Acme Blue Label dowel, 1/2 x 2"	2CK-D6	3CK-D6	2
6	Drive housing	2CK-D7	3CK-D7	1
7	Feed drive idler gear shaft	2CK-D8	3CK-D8	1
8	Hyatt brg. 93416	2CK-D9	3CK-D9	1
9	Feed drive idler gear	2CK-D10	3CK-D10	1
10	Timken brg. 08231-08125	2CK-D11	3CK-D11	2
11	Feed cross shaft gear	2CK-D12	3CK-D12	1
12	Feed cross shaft washer	2CK-D13	3CK-D13	1
13	Gurney locknut and washer #3	2CK-D14	3CK-D14	1
14	Feed cross shaft	2CK-D15	3CK-D15	1
15	Feed cross shaft brg sleeve	2CK-D16	3CK-D16	1
16	Fil hd screw, 3/8-16 x 9/16"	2CK-D17	3CK-D17	2
17	Hex hd cap screw, 5/8-11 x 1-1/2"	2CK-D18	3CK-D18	1
18	Lockwasher, 5/8"	2CK-D19	3CK-D19	1
19	Washer	2CK-D20	3CK-D20	1
20	Drive gear adj washer	2CK-D21	3CK-D21	2
21	Timken brg. 453A-462	2CK-D22	3CK-D22	2
22	Drive shaft	2CK-D23	3CK-D23	1
23	Drive gear	2CK-D24	3CK-D24	1
24	Timken brg. 453B-462	2CK-D25	3CK-D25	2
25	Snap ring	2CK-D26	3CK-D26	1
26	Drive shaft brg. adj washer	2CK-D27	3CK-D27	2
27	New Departure brg. NM-0210B	2CK-D28	3CK-D28	4
28	Hex hd cap screw, 5/8-11 x 1-5/8"	2CK-D29	3CK-D29	3
29	Lockwasher, 5/8"	2CK-D30	3CK-D30	**3
30	Drive shaft brg sleeve	2CK-D31	3CK-D31	1
31	Vert drive spiral bevel gear	2CK-D32	3CK-D32	1
32	Hex hd screw, 5/8-11 x 1-1/8"		3CK-D33	3
33	Drive shaft brg sleeve		3CK-D34	1
34	Vert drive spiral bevel gear	2CK-D35	3CK-D35	1
35	Plug	2CK-D36	3CK-D36	1
36	Snap ring, Tru-arc 5100-200	2CK-D37	3CK-D37	1
37	Primary low speed sliding gear	2CK-D38	3CK-D38	1
38	Primary high speed sliding gear	2CK-D39	3CK-D39	1
39	Primary speed change shaft	2CK-D40	3CK-D40	1
40	Hyatt brg. R-1209 T.S.	2CK-D41	3CK-D41	1
41	Brg spacer	2CK-D42	3CK-D42	1
42	Fil hd screw, 1/2-13 x 15/16"	2CK-D43	3CK-D43	4
43	Gits oiler, #409	2CK-D44	3CK-D44	1
44	Primary shaft brg retainer	2CK-D45	3CK-D45	1
45	Drive idler gear	2CK-D46	3CK-D46	1
46	Feed screw oil sleeve	2CK-D47	3CK-D47	1
47	Feed screw oil slinger	2CK-D48	3CK-D48	1
48	Timken brg. 12303-12175	2CK-D49	3CK-D49	2
49	Feed screw nut drive gear	2CK-D50	3CK-D50	1
50	Key	2CK-D51	3CK-D51	1
51	Hd feed nut	2CK-D52	3CK-D52	1
52	Feed screw brg adj washer	2CK-D53	3CK-D53	1
53	Feed screw cover	2CK-D54	3CK-D54	1
54	Countershaft cover	2CK-D55	3CK-D55	1
55	Countershaft drive gear adj washer	2CK-D56	3CK-D56	1
56	Timken brg. 3920-3982	2CK-D57	3CK-D57	1
57	Spindle countershaft drive gear	2CK-D58	3CK-D58	1

Item No.	Part Name and Description	Code Nos.		Qty.
		2CK	3CK	
58	Timken brg. 3920B-3984	2CK-D59	3CK-D59	1
59	Countershaft oil sleeve	2CK-D60	3CK-D60	1
60	Range change cam shaft	2CK-D61	3CK-D61	1
61	Hi-pro key, HP-605	2CK-D62	3CK-D62	2
62	Washer	2CK-D63	3CK-D63	1
63	Cotter pin, 1-3/32 x 3/4"	2CK-D64	3CK-D64	1
64	Range change shifter pin	2CK-D65	3CK-D65	1
65	Range change cam	2CK-D66	3CK-D66	1
66	Torrington brg. B-1616	2CK-D67	3CK-D67	2
67	Range change pinion	2CK-D68	3CK-D68	1
68	Tru-arc snap ring, 5100-100	2CK-D69	3CK-D69	1
69	Range change link stud	2CK-D70	3CK-D70	1
70	Hex nut, 1"-14 L.H.	2CK-D71	3CK-D71	1
71	Range change counterweight	2CK-D72	3CK-D72	1
72	Hex nut, 1"-14 R.H.	2CK-D73	3CK-D73	1
73	Range change link stud	2CK-D74	3CK-D74	1
74	Range change link pin	2CK-D75	3CK-D75	1
75	Cotter pin, 1/16 x 3/4"	2CK-D76	3CK-D76	2
76	Speed gear shifter lever	2CK-D77	3CK-D77	1
77	Gear shifter compensating lever	2CK-D78	3CK-D78	1
78	Compensating lever pin	2CK-D79	3CK-D79	1
79	Shifter link pin	2CK-D80		2
80	Cotter pin, 1/16 x 3/4"	2CK-D81		2
81	Clutch shifter shoe		3CK-D82	2
82	Acme Blue Label dowel, 3/4 x 1-5/8"	2CK-D83		2
82	Acme Blue Label dowel, 3/4 x 2"		3CK-D83	2
83	Compensating rod sleeve	2CK-D84	3CK-D84	1
84	Sleeve adj washer	2CK-D85	3CK-D85	2
85	Shifter rod sleeve	2CK-D86	3CK-D86	1
86	Hex hd cap screw, 1/2-13 x 5"		3CK-D87	2
87	Garlock chevron packing top adapter ring, 1-31/64 OD x 63/64ID	2CK-D88	3CK-D88	2
88	Garlock chevron packing ring, 1-31/64OD x 63/64ID	2CK-D89	3CK-D89	2
89	Garlock chevron packing bottom adapter ring, 1-31/64OD x 63/64ID	2CK-D90	3CK-D90	2
90	Hex hd cap screw, 3/8-16 x 1"	2CK-D91		2
91	Drive brg plate cover	2CK-D92	3CK-D92	1
92	Hex hd cap screw, 1/2-13 x 2-1/2"		3CK-D93	2
93	Fil hd screw, 5/8-11 x 1-3/4"	2CK-D94		9
93	Hex hd cap screw, 1/2-13 x 2-3/16"		3CK-D94	8
94	Fil hd screw, 7/16-14 x 7/8"	2CK-D95	3CK-D95	**9
95	Acme Blue Label dowel, 1/2 x 1-3/4"	2CK-D96		2
95	Acme Blue Label dowel, 1/2 x 2-1/2"		3CK-D96	2
96	Drive brg plate	2CK-D97	3CK-D97	1
97	Range change rack	2CK-D98	3CK-D98	1
98	Range change yoke	2CK-D99	3CK-D99	1
99	Taper pin screw	2CK-D100	3CK-D100	1
100	Garlock packing carrier	2CK-D101		1
101	Pipe plug, 1"	2CK-D102	3CK-D102	1
102	Vert column	2CK-D103	3CK-D103	1
103	Rod packing retainer	2CK-D104		1
104	Flat hd mach screw, 10-32 x 1/2"	2CK-D105		3
105	Column hole plug	2CK-D106	3CK-D106	1
106	Clamp rod	2CK-D107	3CK-D107	1
107	Column vent plate	2CK-D108	3CK-D108	1
108	Fil hd screw, 3/8-16 x 7/8"	2CK-D109	3CK-D109	5
109	Oval hd screw, 10-32 x 3/4"	2CK-D110	3CK-D110	2
110	Name plate	2CK-D111	3CK-D111	1
111	Pipe plug, 1-1/2"	2CK-D112	3CK-D112	1

*Fifteen used on No. 3 machines.
**Six used on No. 3 machines



WHEN ORDERING PARTS
REPORT SERIAL NUMBER
SHOWN ON THIS PLATE

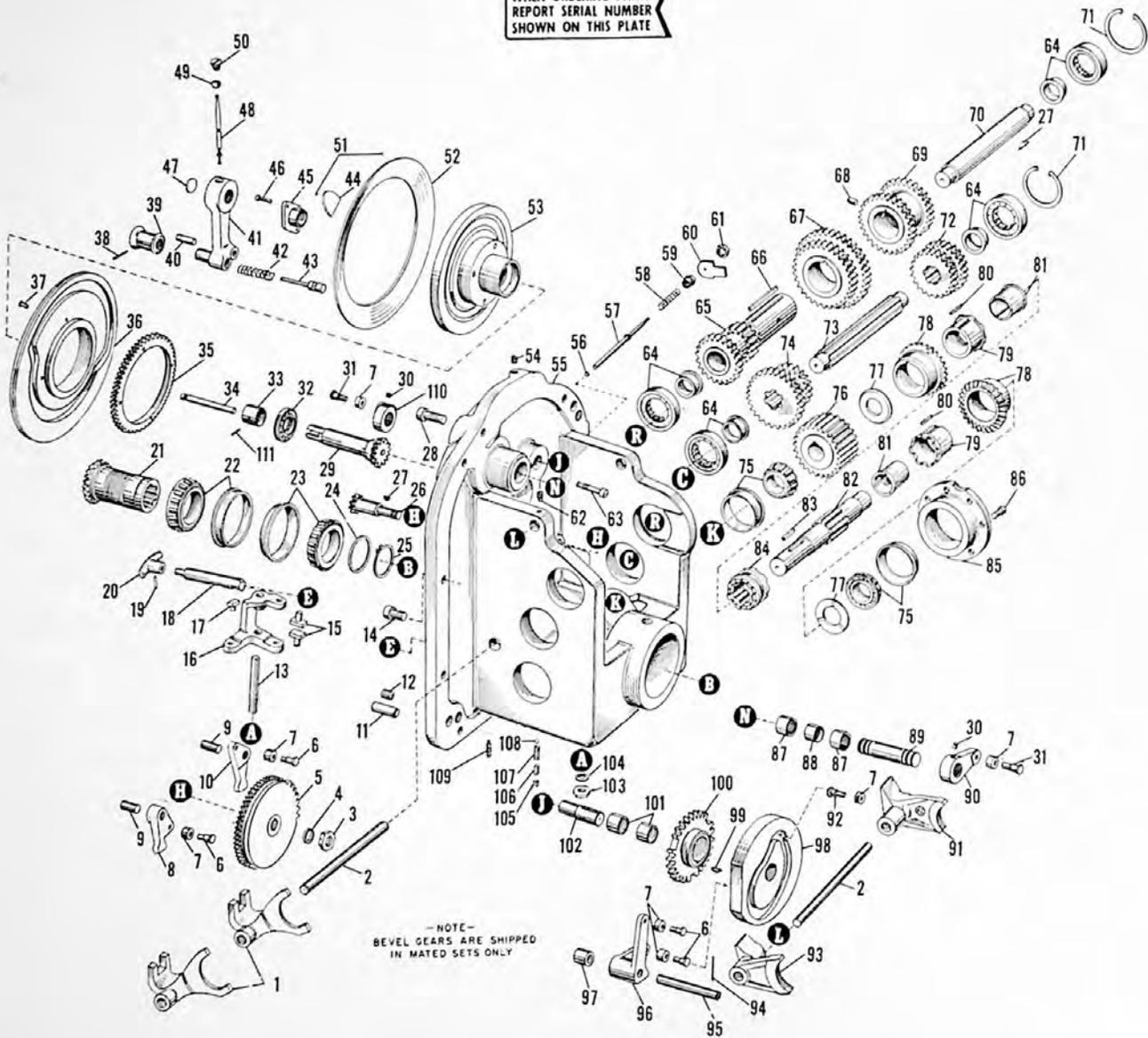

FIG. 9 - SPEED GEAR BOX

Replacement Parts Manual

Milling Machines—Plain, Universal and Vertical

Fig. 9 - Speed Gear Box

Item No.	Part Name and Description	Code Nos.		Qty.
		2CK	3CK	
1	Secondary speed shifter fork	2CK-E1	3CK-E1	2
2	Speed shifter fork shaft	2CK-E2	3CK-E2	2
3	Hex nut, 3/4-10	2CK-E3	3CK-E3	1
4	Lockwasher, 3/4"	2CK-E4	3CK-E4	1
5	Secondary speed change cam	2CK-E5	3CK-E5	1
6	Speed selection roller pin	2CK-E6	3CK-E6	4
7	Speed selection roller	2CK-E7	3CK-E7	7
8	Secondary speed shifter crank (Front)	2CK-E8	3CK-E8	1
9	Acme Blue Label dowel, 5/8 x 1-1/2"	2CK-E9	3CK-E9	2
10	Secondary speed shifter crank (Rear)	2CK-E10	3CK-E10	1
11	Acme Blue Label dowel, 5/8 x 1-3/4"	2CK-E11	3CK-E11	2
12	Socket set screw, 5/8 x 1"	2CK-E12	3CK-E12	2
13	Spindle reverse shifter yoke stud	2CK-E13	3CK-E13	1
14	Socket hd cap screw, 1/2 x 1-1/4"	2CK-E14	3CK-E14	10
15	Shoe	2CK-E15	3CK-E15	2
16	Spindle reverse shifter yoke	2CK-E16	3CK-E16	1
17	Shoe	2CK-E17	3CK-E17	1
18	Spindle reverse rod	2CK-E18	3CK-E18	1
19	Taper pin, #3 x 3/4"	2CK-E19	3CK-E19	1
20	Spindle reverse knob	2CK-E20	3CK-E20	1
21	Spindle drive bevel gear	2CK-E21	3CK-E21	1
22	Timken brg. 382B-387	2CK-E22	3CK-E22	1
23	Timken brg. 382B-389	2CK-E23	3CK-E23	1
24	Fitting washer	2CK-E24	3CK-E24	1
25	Snap ring, Tru-arc 5100-215	2CK-E25	3CK-E25	1
26	Speed dial plate pinion	2CK-E26	3CK-E26	1
27	Key, HP-606	2CK-E27	3CK-E27	2
28	Socket hd cap screw, 1/2 x 2"	2CK-E28	3CK-E28	1
29	Speed change pinion	2CK-E29	3CK-E29	1
30	Socket set screw, 1/4-20 x 5/16"	2CK-E30	3CK-E30	2
31	Range change roller pin	2CK-E31	3CK-E31	2
32	New Departure brg. 3LO6	2CK-E32	3CK-E32	1
33	Switch trip cam	2CK-E33	3CK-E33	1
34	Valve stem	2CK-E34	3CK-E34	1
35	Speed dial plate gear	2CK-E35	3CK-E35	1
36	Speed dial plate and cam	2CK-E36	3CK-E36	1
37	Csunk rivet, 1/4 x 1"	2CK-E37	3CK-E37	4
38	Taper pin, #2 x 1"	2CK-E38	3CK-E38	1
39	Speed selection knob	2CK-E39	3CK-E39	1
40	Speed selection lever pin	2CK-E40	3CK-E40	1
41	Speed selection lever	2CK-E41	3CK-E41	1
42	Spring	2CK-E42	3CK-E42	1
43	Speed selection lever plunger	2CK-E43	3CK-E43	1
44	Speed indicator plate	2CK-E44	3CK-E44	1
45	Speed change pinion brg	2CK-E45	3CK-E45	1
46	Fil hd screw, 5/16-18 x 11/16"	2CK-E46	3CK-E46	2
47	Expansion plug, 1" diam	2CK-E47	3CK-E47	1
48	Valve operating arm	2CK-E48	3CK-E48	1
49	Fulcrum ball	2CK-E49	3CK-E49	1
50	Speed selection lever screw	2CK-E50	3CK-E50	1
51	Escutcheon pin, #15	2CK-E51	3CK-E51	19
52	Speed selection dial	2CK-E52	3CK-E52	1
53	Speed dial brg	2CK-E53	3CK-E53	1
54	Set screw, 1/2-13 x 1/2"	2CK-E54	3CK-E54	1
55	Speed box	2CK-E55	3CK-E55	1
56	Steel ball, 3/8" diam	2CK-E56	3CK-E56	1

Item No.	Part Name and Description	Code Nos.		Qty.
		2CK	3CK	
57	Switch rod	2CK-E57	3CK-E57	1
58	Spring	2CK-E58	3CK-E58	1
59	Switch rod spring retainer	2CK-E59	3CK-E59	1
60	Switch contact arm	2CK-E60	3CK-E60	1
61	Hex nut, 1/4-20	2CK-E61	3CK-E61	1
62	Dog pt set screw, 3/8-16 x 9/16"	2CK-E62	3CK-E62	1
63	Fil hd screw, 3/8-16 x 1-15/16"	2CK-E63	3CK-E63	3
64	Hyatt brg. R-1306TS	2CK-E64	3CK-E64	4
65	Front idler cluster gear	2CK-E65	3CK-E65	1
66	Key	2CK-E66	3CK-E66	1
67	Center idler cluster gear	2CK-E67	3CK-E67	1
68	Pin	2CK-E68	3CK-E68	1
69	Rear idler cluster gear	2CK-E69	3CK-E69	1
70	Speed change idler shaft	2CK-E70	3CK-E70	1
71	Snap ring, Tru-arc 5100-215	2CK-E71	3CK-E71	2
72	Rear secondary sliding gear	2CK-E72	3CK-E72	1
73	Secondary speed change shaft	2CK-E73	3CK-E73	1
74	Front secondary sliding gear	2CK-E74	3CK-E74	1
75	Timken brg. 2523B-2580	2CK-E75	3CK-E75	2
76	Range drive pinion	2CK-E76	3CK-E76	1
77	Reverse bevel gear thrust collar	2CK-E77	3CK-E77	2
78	Spindle reverse bevel gear	2CK-E78	3CK-E78	2
79	Spindle reverse bevel gear clutch	2CK-E79	3CK-E79	2
80	Clutch key	2CK-E80	3CK-E80	2
81	Spindle reverse bevel gear clutch bushing	2CK-E81	3CK-E81	2
82	Reverse bevel gear shaft	2CK-E82	3CK-E82	1
83	Pinion key	2CK-E83	3CK-E83	1
84	Spindle reverse clutch	2CK-E84	3CK-E84	1
85	Reverse bevel gear shaft brg carrier	2CK-E85	3CK-E85	1
86	Socket hd cap screw, 3/8 x 7/8"	2CK-E86	3CK-E86	6
87	Torrington brg. BH-1616X	2CK-E87	3CK-E87	2
88	Bearing spacer	2CK-E88	3CK-E88	1
89	Primary range change shaft	2CK-E89	3CK-E89	1
90	Range change shifter arm	2CK-E90	3CK-E90	1
91	Primary high speed & intermediate shifter fork	2CK-E91	3CK-E91	1
92	Speed selection roller pin	2CK-E92	3CK-E92	1
93	Primary low speed shifter fork	2CK-E93	3CK-E93	1
94	Cotter pin, 1/8 x 1-3/4"	2CK-E94	3CK-E94	1
95	Primary shifter crank shaft	2CK-E95	3CK-E95	1
96	Primary low speed shifter crank	2CK-E96	3CK-E96	1
97	Speed crank spacer	2CK-E97	3CK-E97	1
98	Primary speed change cam	2CK-E98	3CK-E98	1
99	Hi-pro key, HP-908	2CK-E99	3CK-E99	1
100	Primary speed cam gear	2CK-E100	3CK-E100	1
101	Primary speed cam bushing	2CK-E101	3CK-E101	2
102	Primary speed cam shaft	2CK-E102	3CK-E102	1
103	Hex nut, 5/8-18	2CK-E103	3CK-E103	1
104	Lockwasher, 5/8"	2CK-E104	3CK-E104	1
105	Set screw, 3/8-16 x 3/16"	2CK-E105	3CK-E105	1
106	Pin	2CK-E106	3CK-E106	1
107	Spring	2CK-E107	3CK-E107	1
108	Steel ball, 5/16" diam	2CK-E108	3CK-E108	1
109	Dog pt set screw, 3/8-16 x 1-3/16"	2CK-E109	3CK-E109	1
110	Range change cam arm	2CK-E110	3CK-E110	1
111	Valve pin	2CK-E111	3CK-E111	1

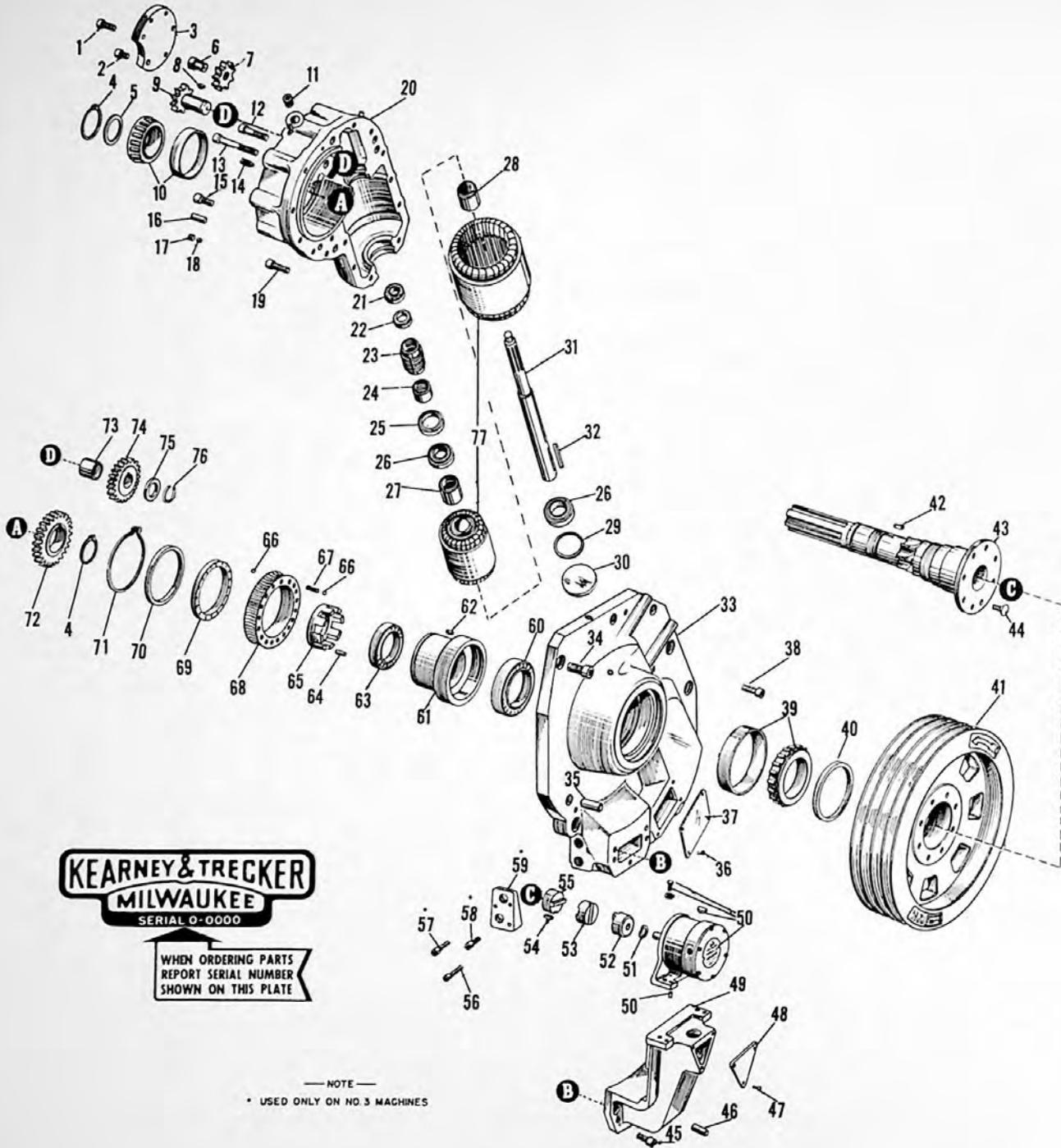

KEARNEY & TRECKER
MILWAUKEE
 SERIAL 0-0000

WHEN ORDERING PARTS
 REPORT SERIAL NUMBER
 SHOWN ON THIS PLATE

NOTE
 * USED ONLY ON NO. 3 MACHINES

FIG. 10 - PULLEY BRACKET

Replacement Parts Manual

Milling Machines—Plain, Universal and Vertical

Fig. 10 - Pulley Bracket

Item No.	Part Name and Description	Code Nos.		Qty.
		2CK-	3CK-	
1	Sock hd cap screw, 3/8 x 7/8"	2CK-F1	3CK-F1	5
2	Sock hd cap screw, 3/8 x 1/2"	2CK-F2	3CK-F2	1
3	Oil pump cover	2CK-F3	3CK-F3	1
4	Snap ring	2CK-F4	3CK-F4	2
5	Pulley shaft fitting washer	2CK-F5	3CK-F5	1
6	Oil pump gear stud	2CK-F6	3CK-F6	1
7	Oil pump gear (Driven)	2CK-F7	3CK-F7	1
8	Hi-pro key, HP-505	2CK-F8	3CK-F8	1
9	Oil pump gear (Driver)	2CK-F9	3CK-F9	1
10	Timken brg, 25521-25581	2CK-F10	3CK-F10	1
11	Pipe plug, 3/8"	2CK-F11	3CK-F11	2
12	Sock hd cap screw, 3/8 x 2-1/4"	2CK-F12	3CK-F12	1
13	Sock hd cap screw, 3/8 x 3-1/4"	2CK-F13	3CK-F13	4
14	Dog pt set screw, 3/8-16 x 15/16"	2CK-F14	3CK-F14	1
15	Sock hd cap screw, 3/8 x 1"	2CK-F15	3CK-F15	2
16	Acme Blue Label dowel, 1/2 x 1-3/4"	2CK-F16	3CK-F16	2
17	Set screw, 3/8-24 x 3/8"	2CK-F17	3CK-F17	2
18	Bronze shoe	2CK-F18	3CK-F18	2
19	Sock hd cap screw, 3/8 x 2"	2CK-F19	3CK-F19	7
20	Synchro-mesh motor bracket	2CK-F20	3CK-F20	1
21	New Departure brg, 3202	2CK-F21	3CK-F21	1
22	Worm spacer	2CK-F22	3CK-F22	1
23	Synchro-mesh worm	2CK-F23	3CK-F23	1
24	Oil seal bushing	2CK-F24	3CK-F24	1
25	Oil seal, National #50344	2CK-F25	3CK-F25	1
26	New Departure brg, 88505	2CK-F26	3CK-F26	2
27	Motor shaft spacer (Long)	2CK-F27	3CK-F27	1
28	Motor shaft spacer (Short)	2CK-F28	3CK-F28	1
29	Fitting washer	2CK-F29	3CK-F29	1
30	Synchro-mesh motor shaft bearing cover	2CK-F30	3CK-F30	1
31	Synchro-mesh motor shaft	2CK-F31	3CK-F31	1
32	Key	2CK-F32	3CK-F32	1
33	Pulley bracket	2CK-F33	3CK-F33	1
34	Sock hd cap screw, 5/8 x 1-1/2"	2CK-F34	3CK-F34	5
35	Acme Blue Label dowel, 5/8 x 2	2CK-F35	3CK-F35	2
36	Flat hd screw, 10-32 x 3/8"	2CK-F36	3CK-F36	4
37	Synchro motor junction cover	2CK-F37	3CK-F37	1
38	Sock hd cap screw, 3/8 x 1-1/4"	2CK-F38	3CK-F38	1
39	Timken brg, 394A-395A	2CK-F39	3CK-F39	1
40	Adjusting washer	2CK-F40	3CK-F40	1
41	Pulley	2CK-F41	3CK-F41	1

Item No.	Part Name and Description	Code Nos.		Qty.
		2CK	3CK	
42	Key	2CK-F42	3CK-F42	1
43	Pulley shaft	2CK-F43	3CK-F43	1
44	Twist off screw	2CK-F44	3CK-F44	8
45	Sock hd cap screw, 3/8 x 1"	2CK-F45	3CK-F45	3
46	Acme Blue Label dowel, 5/16 x 1-1/4"	2CK-F46	3CK-F46	2
47	Button hd screw, 10-32 x 1/2"	2CK-F47	3CK-F47	3
48	Switch support bracket cover	2CK-F48	3CK-F48	1
49	Plugging switch support bracket	2CK-F49	3CK-F49	1
50	Zero speed switch, Allen-Bradley #Y-5789D	2CK-F50		1
50	Zero speed switch, Allen-Bradley #Y-5789		3CK-F50	1
51	Fitting washer for plugging switch	2CK-F51	3CK-F51	1
52	Plugging switch coupling (Driven)	2CK-F52	3CK-F52	1
53	Plugging switch connector coupling	2CK-F53	3CK-F53	1
54	Key	2CK-F54	3CK-F54	1
55	Plugging switch driver coupling	2CK-F55	3CK-F55	1
56	Sock hd cap screw, 10-24 x 1"		3CK-F56	1
57	Sock hd cap screw, 10-24 x 3/4"		3CK-F57	1
58	Sock hd cap screw, 10-24 x 5/8"		3CK-F58	1
59	Conduit adapter		3CK-F59	1
60	New Departure brg, OL12	2CK-F60	3CK-F60	1
61	Synchro-mesh clutch body	2CK-F61	3CK-F61	1
62	Key	2CK-F62	3CK-F62	1
63	New Departure brg, OL09	2CK-F63	3CK-F63	1
64	Synchro-mesh clutch roller	2CK-F64	3CK-F64	8
65	Synchro-mesh roller cage	2CK-F65	3CK-F65	1
66	Steel ball, 5/16" diam	2CK-F66	3CK-F66	36
67	Spring	2CK-F67	3CK-F67	18
68	Synchro-mesh wormwheel	2CK-F68	3CK-F68	1
69	Synchro-mesh clutch back plate	2CK-F69	3CK-F69	1
70	Fitting washer	2CK-F70	3CK-F70	1
71	Snap ring, Tru-arc 5100-334	2CK-F71	3CK-F71	1
72	Pump drive gear (Driver)	2CK-F72	3CK-F72	1
73	Oilite brg, A-1212-2	2CK-F73	3CK-F73	1
74	Pump drive gear (Driven)	2CK-F74	3CK-F74	1
75	Fitting washer	2CK-F75	3CK-F75	1
76	Snap ring	2CK-F76	3CK-F76	1
77	Motor, Louis Allis, shaftless, shell type, 1/2 hp, frame #413 (See motor nameplate)	2CK-F77	3CK-F77	1

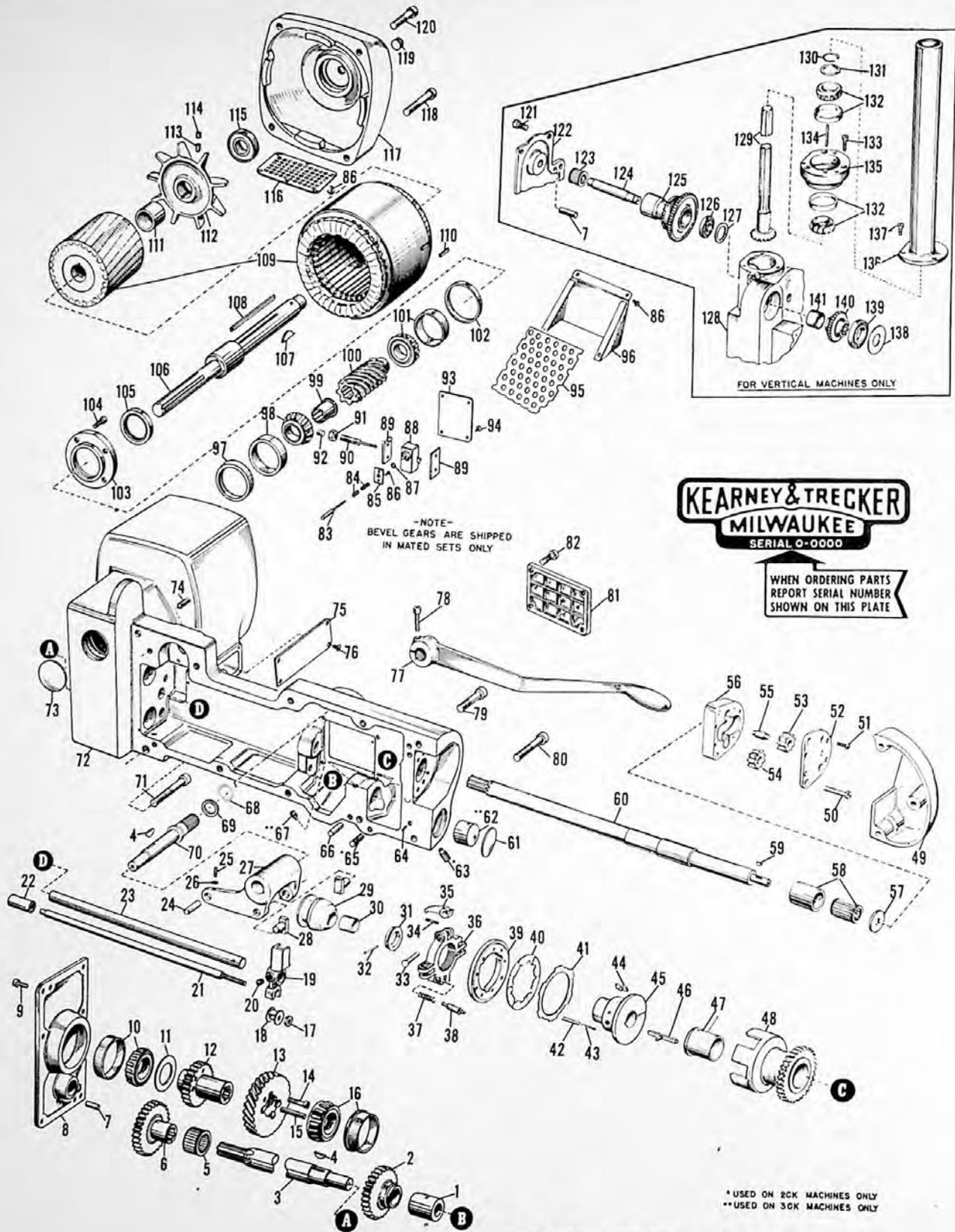

FIG. 11 - FEED AND RAPID TRAVERSE DRIVE BRACKET

Replacement Parts Manual

Milling Machines—Plain, Universal and Vertical

Fig. 11- Feed And Rapid Traverse Drive Bracket

Item No.	Part Name and Description	Code Nos.			Item No.	Part Name and Description	Code Nos.		
		2CK	3CK	Qty.			2CK	3CK	Qty.
1	Feed drive shaft brg (Outer)	2CK-G1	3CK-G1	1	71	Sock hd cap screw, 1/2 x 3-3/4"	2CK-G71		3
2	Main feed drive pinion	2CK-G2	3CK-G2	1	71	Sock hd cap screw, 1/2 x 3-1/2"		3CK-G71	4
3	Feed drive shaft	2CK-G3	3CK-G3	1	72	Feed and rapid traverse drive bracket (Plain mach)	2CK-G72	3CK-G72	1
4	Hi-pro key, HP-806	2CK-G4	3CK-G4	2	73	Expansion plug, 2-1/4"	2CK-G73		1
5	Bantam brg, 223020	2CK-G5	3CK-G5	1	73	Expansion plug, 2-1/2"		3CK-G73	1
6	Feed drive gear	2CK-G6	3CK-G6	1	74	Sock set screw, 3/8 x 1-1/2"	2CK-G74	3CK-G74	1
7	Acme Blue Label dowel, 3/8 x 1"	2CK-G7	3CK-G7	2	75	Wiring chamber cover	2CK-G75	3CK-G75	1
8	Drive bracket cover	2CK-G8	3CK-G8	1	76	Flat hd mach screw, 10-32 x 1/2"	2CK-G76	3CK-G76	4
9	Fl hd screw, 3/8-16 x 7/8"	2CK-G9	3CK-G9	8	77	Rapid traverse lever	2CK-G77	3CK-G77	1
10	Timken brg, 26822-26882	2CK-G10	3CK-G10	1	78	Sock hd cap screw, 3/8 x 1-1/4"	2CK-G78	3CK-G78	1
11	Gear fitting washer	2CK-G11	3CK-G11	1	79	Sock hd cap screw, 1/2 x 1-3/4"	2CK-G79	3CK-G79	1
12	Feed drive pinion	2CK-G12	3CK-G12	1	80	Sock hd cap screw, 1/2 x 2-1/2"	2CK-G80	3CK-G80	1
13	Feed worm wheel	2CK-G13	3CK-G13	1	81	Rapid traverse clutch cover	2CK-G81	3CK-G81	1
14	Sock hd cap screw, 3/8 x 1-1/4"	2CK-G14	3CK-G14	4	82	Fl hd screw, 5/16-18 x 5/8"	2CK-G82	3CK-G82	4
15	Acme Blue Label dowel, 3/8 x 1-5/8"	2CK-G15	3CK-G15	1	83	Switch push rod	2CK-G83	3CK-G83	1
16	Timken brg, 26822B-26882	2CK-G16	3CK-G16	1	84	Spring	2CK-G84	3CK-G84	2
17	Hex nut, 3/8-16"	2CK-G17	3CK-G17	1	85	Push rod spring retainer	2CK-G85	3CK-G85	1
18	Rapid traverse switch yoke spool	2CK-G18	3CK-G18	1	86	Rd hd mach screw, 10-32 x 3/8"	2CK-G86	3CK-G86	12
19	Rapid traverse switch yoke	2CK-G19	3CK-G19	1	87	Snap ring, 3/16" National series #2	2CK-G87	3CK-G87	1
20	Dowel screw, 3/8-16 x 9/16"	2CK-G20	3CK-G20	1	88	Precision limit switch, Allen-Bradley catalog #802, type PBSJ20-11 normally closed	2CK-G88	3CK-G88	1
21	Rapid traverse switch rod	2CK-G21	3CK-G21	1	89	Switch insulating spacer	2CK-G89	3CK-G89	2
22	Oilite bushing, A-604	2CK-G22	3CK-G22	1	90	Switch support rod	2CK-G90	3CK-G90	2
23	Yoke support rod	2CK-G23	3CK-G23	1	91	Hex nut, 3/8-16	2CK-G91	3CK-G91	2
24	Rapid traverse clutch fork pin	2CK-G24	3CK-G24	1	92	Pipe plug, 1/4"	2CK-G92	3CK-G92	2
25	Set screw, 1/4-20 x 25/32"	2CK-G25	3CK-G25	1	93	Switch cover	2CK-G93	3CK-G93	1
26	Hex nut, 1/4"	2CK-G26	3CK-G26	1	94	Rd hd mach screw, 10-32 x 1/2"	2CK-G94	3CK-G94	4
27	Rapid traverse clutch fork	2CK-G27	3CK-G27	1	95	Exhaust screen	2CK-G95	3CK-G95	1
28	Rapid traverse clutch fork shoe	2CK-G28	3CK-G28	2	96	Exhaust baffle	2CK-G96	3CK-G96	1
29	Rapid traverse clutch sliding cone	2CK-G29	3CK-G29	1	97	Worm brg fitting washer	2CK-G97	3CK-G97	1
30	Rapid traverse clutch cone bushing	2CK-G30	3CK-G30	1	98	Timken brg, 02420-02475	2CK-G98	3CK-G98	1
31	Collar	2CK-G31	3CK-G31	1	99	Brg thimble	2CK-G99	3CK-G99	1
32	Taper pin, #3 x 1-5/8"	2CK-G32	3CK-G32	1	100	Feed worm	2CK-G100	3CK-G100	1
33	Rapid traverse clutch finger pin	2CK-G33	3CK-G33	4	101	Timken brg, 16284-16150	2CK-G101	3CK-G101	1
34	Cotter pin, 3/32 x 5/8"	2CK-G34	3CK-G34	4	102	Worm brg fitting washer	2CK-G102	3CK-G102	1
35	Rapid traverse clutch finger (Twin Disc)	2CK-G35	3CK-G35	4	103	Oil seal carrier	2CK-G103	3CK-G103	1
36	Rapid traverse clutch yoke (Twin Disc)	2CK-G36	3CK-G36	1	104	Sock hd cap screw, 3/8 x 3/4"	2CK-G104	3CK-G104	4
37	Spring	2CK-G37	3CK-G37	1	105	Oil seal, Vicroprene #00620	2CK-G105	3CK-G105	1
38	Rapid traverse clutch adj plunger	2CK-G38	3CK-G38	1	106	Motor shaft	2CK-G106	3CK-G106	1
39	Rapid traverse clutch floating plate	2CK-G39	3CK-G39	1	107	Hi-pro key, HP-606	2CK-G107	3CK-G107	1
40	Rapid traverse clutch plate (Twin Disc 1939A)	2CK-G40	3CK-G40	5	108	Key	2CK-G108	3CK-G108	1
41	Rapid traverse clutch plate (Twin Disc 1933)	2CK-G41	3CK-G41	14	109	Ohio shaftless shell type motor, 3 hp, 1500 rpm, Ohio drawing B-90223	2CK-G109	3CK-G109	1
42	Spring	2CK-G42	3CK-G42	6	110	Key	2CK-G110	3CK-G110	2
43	Rapid traverse clutch plate pin	2CK-G43	3CK-G43	6	111	Rotor spacer	2CK-G111	3CK-G111	1
44	Rapid traverse clutch plate key	2CK-G44	3CK-G44	3	112	Motor fan	2CK-G112	3CK-G112	1
45	Rapid traverse clutch hub	2CK-G45	3CK-G45	1	113	Sock dog pt set screw, 5/16 x 5/16"	2CK-G113	3CK-G113	1
46	Key	2CK-G46	3CK-G46	1	114	Sock set screw, 5/16 x 1/4"	2CK-G114	3CK-G114	1
47	Rapid traverse clutch gear bushing	2CK-G47	3CK-G47	1	115	New Departure brg, 88506	2CK-G115	3CK-G115	1
48	Rapid traverse clutch gear	2CK-G48	3CK-G48	1	116	Inlet screen	2CK-G116	3CK-G116	1
49	Feed selection cam housing	2CK-G49	3CK-G49	1	117	Motor end bell	2CK-G117	3CK-G117	1
50	Fl hd screw, 1/4-20 x 5/8"	2CK-G50	3CK-G50	4	118	Sock hd cap screw, 1/2 x 3-1/2"	2CK-G118	3CK-G118	2
51	Fl hd screw, 5/16-18 x 1-5/16"	2CK-G51	3CK-G51	4	119	Pipe plug, 3/8"	2CK-G119	3CK-G119	1
52	Oil pump body cover	2CK-G52	3CK-G52	1	120	Sock hd cap screw, 1/2 x 2-1/4"	2CK-G120	3CK-G120	2
53	Oil pump gear (Driven)	2CK-G53	3CK-G53	1	121	Fl hd screw, 3/8-16 x 7/8"	2CK-G121	3CK-G121	9
54	Oil pump gear (Driver)	2CK-G54	3CK-G54	1	122	Drive bracket cover	2CK-G122	3CK-G122	1
55	Oil pump stud	2CK-G55	3CK-G55	1	123	Hyatt brg, 93316	2CK-G123	3CK-G123	1
56	Oil pump body	2CK-G56	3CK-G56	1	124	Feed drive bevel gear shaft	2CK-G124	3CK-G124	1
57	Rapid traverse clutch shaft collar	2CK-G57	3CK-G57	1	125	Vert hd feed gear assy	2CK-G125	3CK-G125	1
58	Hyatt brg, S-93524	2CK-G58	3CK-G58	1	126	New Departure brg, 20203	2CK-G126	3CK-G126	1
59	Hi-pro key, HP-404	2CK-G59	3CK-G59	1	127	Fitting washer	2CK-G127	3CK-G127	1
60	Rapid traverse clutch shaft	2CK-G60	3CK-G60	1	128	Feed and rapid traverse drive bracket (Vert mach)	2CK-G128	3CK-G128	1
61	Expansion plug, 1-3/4"	2CK-G61	3CK-G61	1	129	Vert hd feed bevel gear shaft	2CK-G129	3CK-G129	1
62	Oiling plug		3CK-G62	1	130	Snap ring	2CK-G130	3CK-G130	1
63	Dog pt set screw, 3/8-16 x 1-1/16"	2CK-G63		1	131	Feed shaft brg washer	2CK-G131	3CK-G131	1
64	Half dog pt set screw, 10-32 x 1/4"		3CK-G64	1	132	Timken brg, 1932-1985	2CK-G132	3CK-G132	2
65	Sock set screw, 3/8 x 1"	2CK-G65		1	133	Sock hd cap screw, 5/16 x 1"	2CK-G133		4
66	Acme Blue Label dowel, 3/8 x 2-3/4"	2CK-G66		1	133	Fl hd screw, 5/16-18 x 1"		3CK-G133	3
66	Acme Blue Label dowel, 3/8 x 3-3/4"		3CK-G66	1	134	Oil wicking	2CK-G134	3CK-G134	1
67	Dog pt set screw, 3/8-16 x 11/16"		3CK-G67	1	135	Brg carrier	2CK-G135	3CK-G135	1
68	"O" Ring packing, AN8227-19	2CK-G68	3CK-G68	1	136	Outer telescopic tube and flange	2CK-G136	3CK-G136	1
69	Washer	2CK-G69	3CK-G69	1	137	Fl hd screw, 1/4-20 x 11/16"	2CK-G137		3
70	Rapid traverse lever shaft	2CK-G70	3CK-G70	1	137	Fl hd screw, 1/4-20 x 5/8"		3CK-G137	3
					138	Drive shaft pinion brg washer	2CK-G138	3CK-G138	1
					139	Gurney brg, 106-N	2CK-G139	3CK-G139	1
					140	Drive shaft pinion	2CK-G140	3CK-G140	1
					141	Drive shaft pinion brg	2CK-G141	3CK-G141	1

* Used only on machines with rear control
 † Six used on No. 3 machines

‡ Only 8 used on No. 3 machines
 † Five used on No. 3 machines

▶ Used only on No. 3 vertical machines
 ‡ Two used on No. 3 machines

BUILDERS OF PRECISION AND PRODUCTION

KEARNEY & TRECKER
MILWAUKEE

MACHINE TOOLS FOR MILLING AND BORING

Replacement Parts Manual

10 hp No. 2 and 15 hp No. 3 Model CK

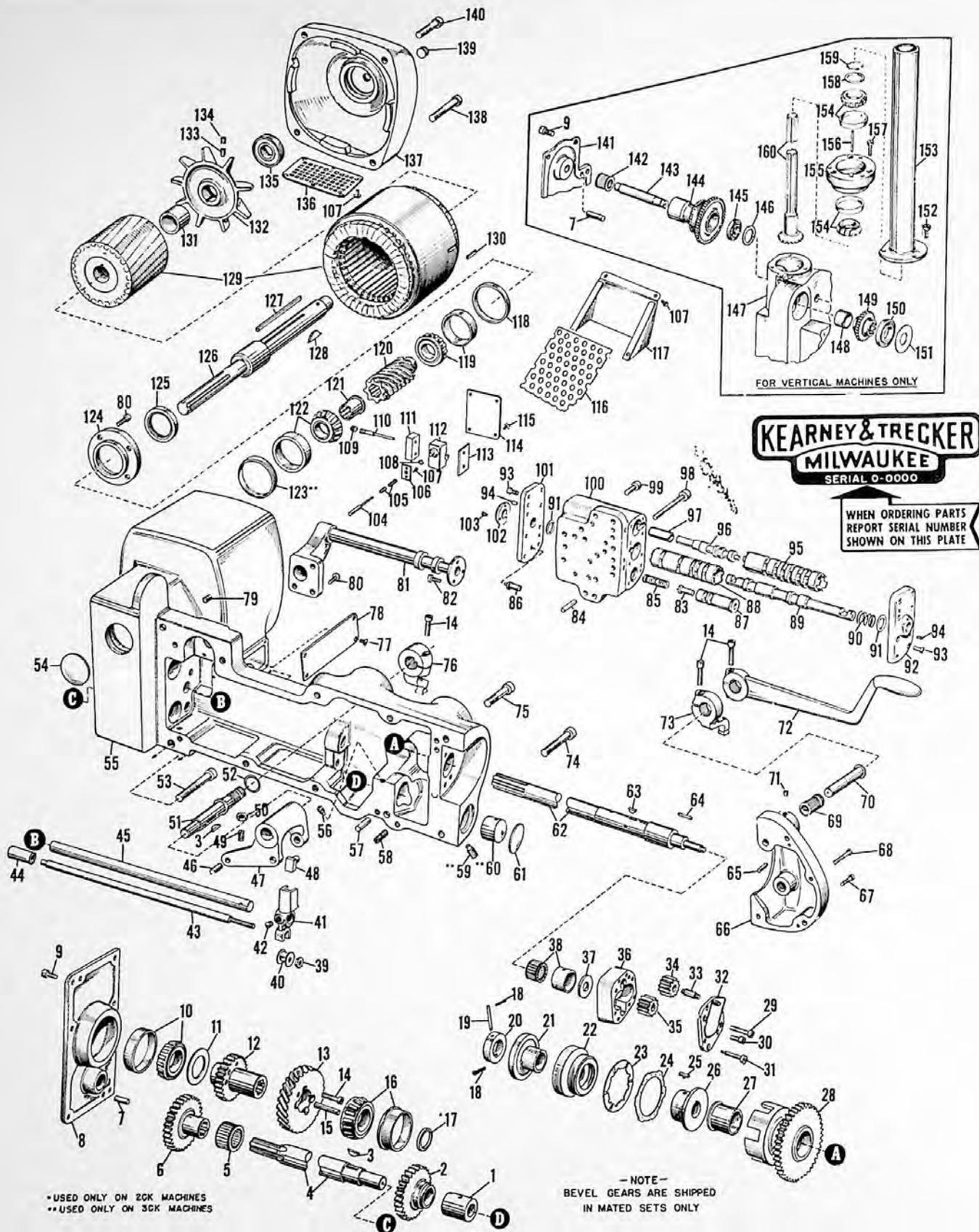

*USED ONLY ON 2CK MACHINES
 **USED ONLY ON 3CK MACHINES

- NOTE -
 BEVEL GEARS ARE SHIPPED
 IN MATED SETS ONLY

FIG. 12 - AUTOMATIC FEED AND RAPID TRAVERSE DRIVE BRACKET

BUILDERS OF PRECISION AND PRODUCTION



MACHINE TOOLS FOR MILLING AND BORING

Fig.12 - Automatic Feed And Rapid Traverse Drive Bracket

Item No.	Part Name and Description	Code Nos.		Qty.
		2CK	3CK	
1	Feed drive shaft brg. (Outer)	2CK-H1	3CK-H1	1
2	Main feed drive pinion	2CK-H2	3CK-H2	1
3	Hi-pro key. HP-806	2CK-H3	3CK-H3	2
4	Feed drive shaft	2CK-H4	3CK-H4	1
5	Bantam brg. 223020	2CK-H5	3CK-H5	1
6	Feed drive gear	2CK-H6	3CK-H6	1
7	Acme Blue Label dowel. 3/8 x 1"	2CK-H7	3CK-H7	2
8	Drive bracket cover (Plain mach)	2CK-H8	3CK-H8	1
9	Fil hd screw. 3/8-16 x 7/8"	2CK-H9	3CK-H9	* 8
10	Timken brg. 26822-26882	2CK-H10	3CK-H10	1
11	Gear fitting washer	2CK-H11	3CK-H11	1
12	Feed drive pinion	2CK-H12	3CK-H12	1
13	Feed worm wheel	2CK-H13	3CK-H13	1
14	Sock cap screw. 3/8 x 1-1/4"	2CK-H14	3CK-H14	7
15	Acme Blue Label dowel. 3/8 x 1-5/8"	2CK-H15	3CK-H15	1
16	Timken brg. 26822B-26878	2CK-H16	3CK-H16	1
17	Rapid traverse shaft thrust collar	2CK-H17		1
18	Cotter pin. 3/32 x 1/2"	2CK-H18	3CK-H18	2
19	Rapid traverse shaft collar pin	2CK-H19	3CK-H19	1
20	Rapid traverse shaft collar	2CK-H20	3CK-H20	1
21	Rapid traverse operating sleeve	2CK-H21	3CK-H21	1
22	Clutch engage sleeve	2CK-H22	3CK-H22	1
23	Rapid traverse clutch plate (Twin Disc 1939A)	2CK-H23	3CK-H23	8
24	Rapid traverse clutch plate (Twin Disc 1933)	2CK-H24	3CK-H24	8
25	Rapid traverse clutch plate key	2CK-H25	3CK-H25	3
26	Rapid traverse clutch hub	2CK-H26	3CK-H26	1
27	Rapid traverse clutch gear bushing	2CK-H27	3CK-H27	1
28	Rapid traverse clutch gear	2CK-H28	3CK-H28	1
29	Sock cap screw. 5/16 x 1-3/4"	2CK-H29	3CK-H29	2
30	Sock cap screw. 1/4 x 5/8"	2CK-H30	3CK-H30	4
31	Allen shoulder screw. 5/16 x 1-3/4"	2CK-H31	3CK-H31	2
32	Oil pump cover	2CK-H32	3CK-H32	1
33	Oil pump gear stud	2CK-H33	3CK-H33	1
34	Oil pump gear (Driven)	2CK-H34	3CK-H34	1
35	Oil pump gear (Driver)	2CK-H35	3CK-H35	1
36	Oil pump body	2CK-H36	3CK-H36	1
37	Rapid traverse clutch shaft collar	2CK-H37	3CK-H37	1
38	Hyatt brg. S-93516	2CK-H38	3CK-H38	1
39	Hex nut. 3/8-16"	2CK-H39	3CK-H39	1
40	Rapid traverse switch yoke spool	2CK-H40	3CK-H40	1
41	Rapid traverse switch yoke	2CK-H41	3CK-H41	1
42	Dog pt set screw. 3/8-16 x 9/16"	2CK-H42	3CK-H42	1
43	Rapid traverse switch rod	2CK-H43	3CK-H43	1
44	Oilite brg. A-604	2CK-H44	3CK-H44	1
45	Yoke support rod	2CK-H45	3CK-H45	1
46	Rapid traverse clutch fork pin	2CK-H46	3CK-H46	1
47	Rapid traverse clutch fork	2CK-H47	3CK-H47	1
48	Rapid traverse clutch fork shoe	2CK-H48	3CK-H48	1
49	Set screw. 1/4-20 x 25/32"	2CK-H49	3CK-H49	1
50	Hex nut. 1/4-20"	2CK-H50	3CK-H50	1
51	Rapid traverse lever shaft	2CK-H51	3CK-H51	1
52	"O" Ring packing. AN-6227-19	2CK-H52	3CK-H52	1
53	Sock hd cap screw. 1/2 x 3-3/4"	2CK-H53		3
53	Sock hd cap screw. 1/2 x 3-1/2"		3CK-H53	3
54	Expansion plug. 2-1/4"	2CK-H54		1
54	Expansion plug. 2-1/2"		3CK-H54	1
55	Feed and rapid traverse drive bracket (Plain mach)	2CK-H55	3CK-H55	1
56	Dog pt set screw. 3/8-16 x 1-1/16"	2CK-H56		1
56	Dog pt set screw. 3/8-16 x 11/16"		3CK-H56	1

Item No.	Part Name and Description	Code Nos.		Qty.
		2CK	3CK	
57	Acme Blue Label dowel. 3/8 x 2-3/4"	2CK-H57	3CK-H57	2
58	Sock set screw. (Flat pt) 3/8 x 1"	2CK-H58		1
58	Sock set screw. (Flat pt) 3/8 x 1-1/2"		3CK-H58	1
59	Dog pt set screw. 7/16-14 x 1-1/8"		3CK-H59	1
60	Oiling plug		3CK-H60	1
61	Expansion plug. 1-3/4" diam	2CK-H61	3CK-H61	1
62	Rapid traverse clutch shaft	2CK-H62	3CK-H62	1
63	Hi-pro key. HP-708	2CK-H63	3CK-H63	2
64	Rd end key	2CK-H64	3CK-H64	1
65	Acme Blue Label dowel. 1/4 x 2"	2CK-H65		2
65	Acme Blue Label dowel. 1/4 x 1-1/2"		3CK-H65	2
66	Feed selection cam housing	2CK-H66	3CK-H66	1
67	Sock hd screw. 3/8 x 1-1/2"	2CK-H67		3
67	Sock hd screw. 3/8 x 1-1/4"		3CK-H67	3
68	Sock hd screw. 3/8 x 2-3/4"	2CK-H68		1
68	Sock hd screw. 3/8 x 2-1/2"		3CK-H68	1
69	Rapid traverse lever sleeve	2CK-H69	3CK-H69	1
70	Rapid traverse lever pin	2CK-H70	3CK-H70	1
71	Dog pt set screw. 3/8-16 x 13/16"	2CK-H71	3CK-H71	1
72	Rapid traverse lever	2CK-H72	3CK-H72	1
73	Rapid traverse valve shifter (Front)	2CK-H73	3CK-H73	1
74	Sock hd cap screw. 1/2 x 2-1/2"	2CK-H74	3CK-H74	1
75	Sock hd cap screw. 1/2 x 1-3/4"	2CK-H75	3CK-H75	* 4
76	Rapid traverse valve shifter (Rear)	2CK-H76	3CK-H76	1
77	Flat hd mach screw. 10-32 x 1/2"	2CK-H77	3CK-H77	4
78	Wiring chamber cover	2CK-H78	3CK-H78	1
79	Sock set screw. (Flat pt) 3/8 x 1-1/2"	2CK-H79	3CK-H79	1
80	Sock cap screw. 3/8 x 3/4"	2CK-H80	3CK-H80	7
81	Oil return tube and bracket assy	2CK-H81	3CK-H81	1
82	Fil hd screw. 3/16-32 x 3/8"	2CK-H82		3
82	Fil hd screw. 10-32 x 5/16"		3CK-H82	3
83	Relief valve plunger	2CK-H83	3CK-H83	1
84	Acme Blue Label dowel. 3/8 x 1-1/4"	2CK-H84	3CK-H84	2
85	Spring	2CK-H85	3CK-H85	1
86	Pressure relief valve plunger stop	2CK-H86	3CK-H86	1
87	Pressure relief valve sleeve	2CK-H87	3CK-H87	1
88	Rapid traverse control valve sleeve	2CK-H88	3CK-H88	1
89	Rapid traverse control valve piston	2CK-H89	3CK-H89	1
90	Spring	2CK-H90	3CK-H90	1
91	"O" Ring packing. AN-6227-15	2CK-H91	3CK-H91	2
92	Rapid traverse valve body cover (Front)	2CK-H92	3CK-H92	1
93	Sock hd cap screw. 5/16 x 5/8"	2CK-H93	3CK-H93	16
94	Acme Blue Label dowel. 3/16 x 3/4"	2CK-H94	3CK-H94	4
95	Rapid traverse pilot valve sleeve	2CK-H95	3CK-H95	1
96	Pilot valve	2CK-H96	3CK-H96	1
97	Pilot valve sleeve (Short)	2CK-H97	3CK-H97	1
98	Sock hd cap screw. 3/8 x 4"	2CK-H98	3CK-H98	4
99	Sock hd cap screw. 3/8 x 1"	2CK-H99	3CK-H99	3
100	Rapid traverse valve body	2CK-H100	3CK-H100	1
101	Rapid traverse valve body cover (Rear)	2CK-H101	3CK-H101	1
102	Rapid traverse control valve piston wiper	2CK-H102	3CK-H102	1

Item No.	Part Name and Description	Code Nos.		Qty.
		2CK	3CK	
103	Oval hd screw. 10-32 x 15/32"	2CK-H103	3CK-H103	3
104	Micro switch push rod	2CK-H104	3CK-H104	1
105	Spring	2CK-H105	3CK-H105	2
106	Push rod spring retainer	2CK-H106	3CK-H106	1
107	Rd hd mach screw. 10-32 x 3/8"	2CK-H107	3CK-H107	12
108	Snap ring. 3/16 series #2. national	2CK-H108	3CK-H108	1
109	Set screw	2CK-H109	3CK-H109	2
110	Switch support rod	2CK-H110	3CK-H110	2
111	Switch insulating spacer	2CK-H111	3CK-H111	1
112	Precision limit switch. Allen-Bradley catalog #802 type #PBSJ-20-11 normally closed	2CK-H112	3CK-H112	1
113	Switch insulating spacer	2CK-H113	3CK-H113	1
114	Switch cover	2CK-H114	3CK-H114	1
115	Rd hd screw. 10-32 x 1/2"	2CK-H115	3CK-H115	4
116	Exhaust screen	2CK-H116	3CK-H116	1
117	Exhaust baffle	2CK-H117	3CK-H117	1
118	Worm brg fitting washer	2CK-H118	3CK-H118	1
119	Timken brg. 16284-16150	2CK-H119	3CK-H119	1
120	Feed worm	2CK-H120	3CK-H120	1
121	Brg thimble	2CK-H121	3CK-H121	1
122	Timken brg. 02420-02475	2CK-H122	3CK-H122	1
123	Worm spacing washer		3CK-H123	1
124	Oil seal carrier	2CK-H124	3CK-H124	1
125	Victoprene oil seal. 60620	2CK-H125	3CK-H125	1
126	Motor shaft	2CK-H126	3CK-H126	1
127	Rotor key	2CK-H127	3CK-H127	1
128	Hi-pro key. HP-606	2CK-H128	3CK-H128	1
129	Ohio shaftless shell type motor. 3 hp. 1500 rpm. Ohio drawing B-90223	2CK-H129	3CK-H129	1
130	Key	2CK-H130	3CK-H130	1
131	Rotor spacer	2CK-H131	3CK-H131	1
132	Motor fan	2CK-H132	3CK-H132	1
133	Sock dog pt set screw. 5/16 x 5/16"	2CK-H133	3CK-H133	1
134	Sock set screw. 5/16 x 1/4"	2CK-H134	3CK-H134	1
135	New Departure brg. 88506	2CK-H135	3CK-H135	1
136	Inlet screen	2CK-H136	3CK-H136	1
137	Motor end bell	2CK-H137	3CK-H137	1
138	Sock cap screw. 1/2 x 3-1/2"	2CK-H138	3CK-H138	2
139	Slotted pipe plug. 3/8"	2CK-H139	3CK-H139	1
140	Sock cap screw. 1/2 x 2-1/4"	2CK-H140	3CK-H140	2
141	Drive bracket cover (Vert mach)	2CK-H141	3CK-H141	1
142	Hyatt brg. 93316	2CK-H142	3CK-H142	1
143	Feed drive bevel gear shaft	2CK-H143	3CK-H143	1
144	Vert hd feed gear assy	2CK-H144	3CK-H144	1
145	New Departure brg. 20203	2CK-H145	3CK-H145	1
146	Fitting washer	2CK-H146	3CK-H146	1
147	Feed and rapid traverse drive bracket (Vert mach)	2CK-H147	3CK-H147	1
148	Drive shaft pinion brg	2CK-H148	3CK-H148	1
149	Drive shaft pinion	2CK-H149	3CK-H149	1
150	Gurney brg. 106N	2CK-H150	3CK-H150	1
151	Drive shaft pinion brg washer	2CK-H151	3CK-H151	1
152	Fil hd screw. 1/4-20 x 11/16"	2CK-H152		3
152	Fil hd screw. 1/4-20 x 5/8"		3CK-H152	3
153	Outer telescopic tube and flange	2CK-H153	3CK-H153	1
154	Timken brg. 1932-1985	2CK-H154	3CK-H154	2
155	Brg carrier	2CK-H155	3CK-H155	1
156	Oil wicking	2CK-H156	3CK-H156	1
157	Fil hd screw. 5/16-18 x 1"	2CK-H157	3CK-H157	* 4
158	Vert feed shaft brg washer	2CK-H158	3CK-H158	1
159	Snap ring	2CK-H159	3CK-H159	1
160	Vert hd feed bevel gear shaft	2CK-H160	3CK-H160	1

* Nine used on No. 3 machines
 * Five used on No. 3 machines

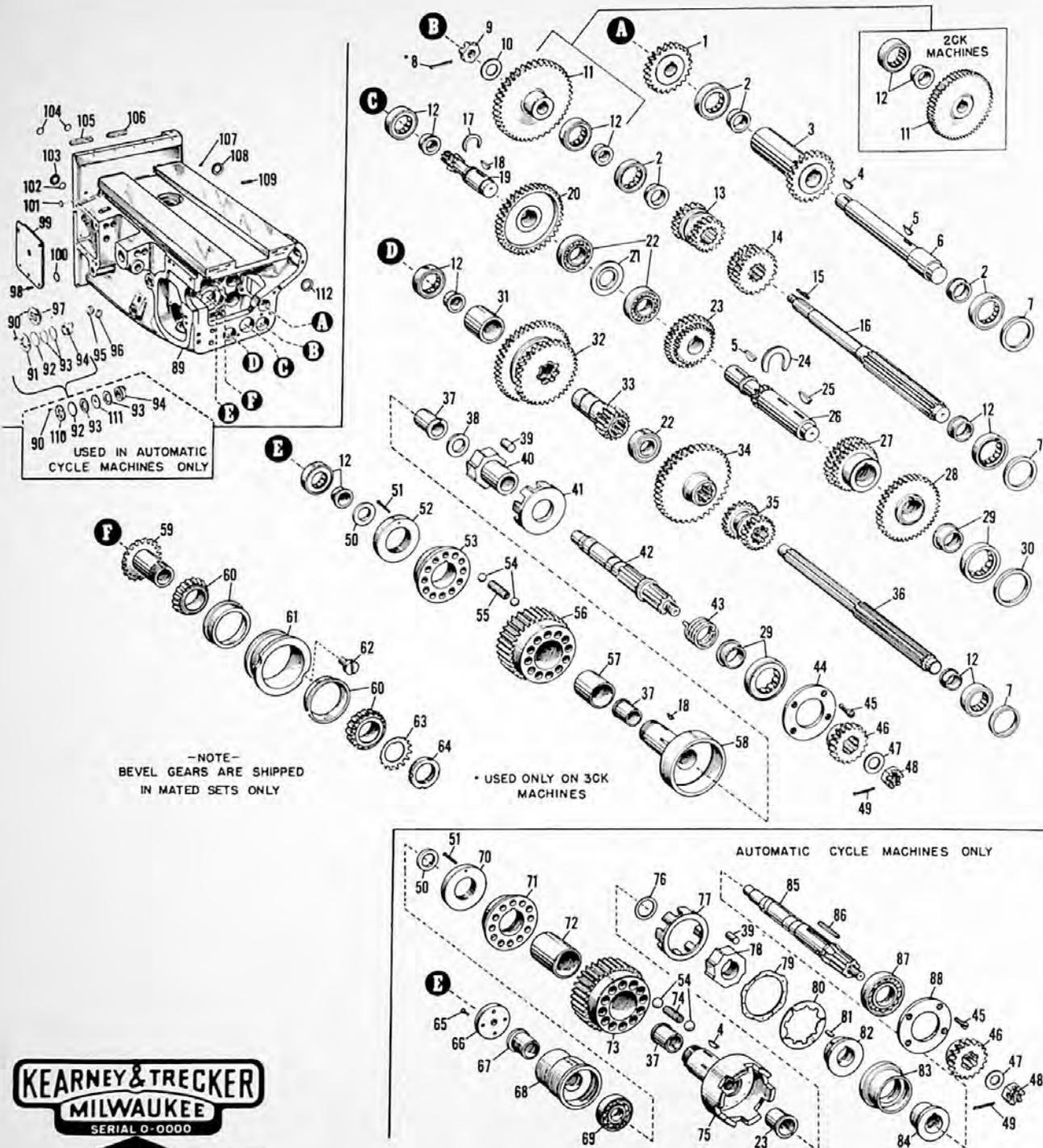

WHEN ORDERING PARTS
REPORT SERIAL NUMBER
SHOWN ON THIS PLATE

FIG. 13 - KNEE (GEAR TRAINS)

Replacement Parts Manual

Milling Machines—Plain, Universal and Vertical

Fig. 13 - Knee (Gear Trains)

Item No.	Part Name and Description	Code Nos.		Qty.
		2CK	3CK	
1	Rapid traverse idler gear (Short)	2CK-J1	3CK-J1	1
2	Hyatt brg. R-1205 T.S.	2CK-J2	3CK-J2	3
3	Rapid traverse idler gear (Long)	2CK-J3	3CK-J3	1
4	Hi-pro key. HP-806	2CK-J4	3CK-J4	1
5	Hi-pro key. HP-806	2CK-J5	3CK-J5	2
6	Rapid traverse idler gear shaft	2CK-J6	3CK-J6	1
7	Primary feed shaft brg washer	2CK-J7	3CK-J7	3
8	Cotter pin. 5/32 x 1-1/2"		3CK-J8	1
9	Castellated nut. 5/8-11	2CK-J9	3CK-J9	1
10	Washer. 5/8"	2CK-J10	3CK-J10	1
11	Primary feed shaft drive gear	2CK-J11	3CK-J11	1
12	Hyatt brg. R-1304 T.S.	2CK-J12	3CK-J12	† 6
13	Primary feed sliding gear (Long)	2CK-J13	3CK-J13	1
14	Primary feed sliding gear (Short)	2CK-J14	3CK-J14	1
15	Hi-pro key. HP-806	2CK-J15		1
15	Key		3CK-J15	1
16	Primary feed shaft	2CK-J16	3CK-J16	1
17	Feed back gear retaining washer	2CK-J17	3CK-J17	1
18	Hi-pro key. HP-706	2CK-J18	3CK-J18	1
19	Feed back gear pinion shaft	2CK-J19	3CK-J19	1
20	Feed back gear	2CK-J20	3CK-J20	1
21	Pinion shaft brg spacer	2CK-J21	3CK-J21	1
22	Hyatt brg U-1205 T.S.	2CK-J22	3CK-J22	3
23	Double gear on secondary feed shaft (Rear)	2CK-J23	3CK-J23	1
24	Secondary feed gear retaining washer	2CK-J24	3CK-J24	1
25	Hi-pro key. HP-1008	2CK-J25	3CK-J25	2
26	Secondary feed shaft	2CK-J26	3CK-J26	1
27	Double gear on secondary feed shaft	2CK-J27	3CK-J27	1
28	Double gear on secondary feed shaft (Front)	2CK-J28	3CK-J28	1
29	Hyatt brg R-1206 T.S.	2CK-J29	3CK-J29	* 2
30	Secondary feed shaft brg washer	2CK-J30	3CK-J30	1
31	Feed sliding double back gear bushing	2CK-J31	3CK-J31	1
32	Feed sliding double back gear	2CK-J32	3CK-J32	1
33	Feed back gear pinion	2CK-J33	3CK-J33	1
34	Tertiary feed sliding gear (Large)	2CK-J34	3CK-J34	1
35	Tertiary feed sliding gear (Small)	2CK-J35	3CK-J35	1
36	Tertiary feed shaft	2CK-J36	3CK-J36	1
37	Feed roller clutch sleeve bushing	2CK-J37	3CK-J37	2
38	Feed safety clutch thrust washer	2CK-J38	3CK-J38	1
39	Feed clutch roller	2CK-J39	3CK-J39	8
40	Feed roller clutch hub	2CK-J40	3CK-J40	1
41	Feed clutch roller cage	2CK-J41	3CK-J41	1
42	Feed safety clutch shaft	2CK-J42	3CK-J42	1
43	Spring	2CK-J43	3CK-J43	1
44	Feed safety clutch shaft washer	2CK-J44	3CK-J44	1
45	Fil hd screw. 5/16-18 x 11/16"	2CK-J45	3CK-J45	4
46	Feed safety clutch shaft pinion	2CK-J46	3CK-J46	1
47	Washer. 5/8"	2CK-J47	3CK-J47	1
48	Castellated nut. 5/8-11"	2CK-J48	3CK-J48	1
49	Cotter pin. 5/32 x 1-1/2"	2CK-J49	3CK-J49	1
50	Feed safety clutch shaft washer	2CK-J50	3CK-J50	1
51	Cotter pin. 1/8 x 1-1/8"	2CK-J51	3CK-J51	1
52	Feed safety clutch sleeve nut	2CK-J52	3CK-J52	1
53	Feed safety clutch end plate	2CK-J53	3CK-J53	1
54	Steel ball. 9/16" diam.	2CK-J54	3CK-J54	* 24
55	Spring	2CK-J55	3CK-J55	* 12
56	Feed safety clutch gear	2CK-J56	3CK-J56	1
57	Feed safety clutch gear bushing	2CK-J57	3CK-J57	1

Item No.	Part Name and Description	Code Nos.		Qty.
		2CK	3CK	
58	Feed roller clutch sleeve	2CK-J58	3CK-J58	1
59	Elevating bevel pinion	2CK-J59	3CK-J59	1
60	Timken brg. 14276B-14137	2CK-J60	3CK-J60	2
61	Elevating bevel pinion brg sleeve	2CK-J61	3CK-J61	1
62	Fil hd screw. 1/2-13 x 3/4"	2CK-J62		2
62	Fil hd screw. 1/2-13 x 1"		3CK-J62	2
63	Gurney lockwasher. #7	2CK-J63	3CK-J63	1
64	Gurney locknut. #7	2CK-J64	3CK-J64	1
65	Sock cap screw. 1/4-20 x 1"	2CK-J65		1
65	Sock cap screw. 1/4-20 x 7/8"	2CK-J66		2
65	Sock cap screw. 1/4-20 x 5/8"	2CK-J67		1
65	Sock cap screw. 1/4 x 1/2"		3CK-J68	4
66	Brg carrier cover	2CK-J69	3CK-J69	1
67	Brg carrier bushing	2CK-J70	3CK-J70	1
68	Safety clutch shaft brg carrier	2CK-J71	3CK-J71	1
69	New Departure brg. 20304	2CK-J72	3CK-J72	1
70	Feed safety clutch sleeve nut	2CK-J73	3CK-J73	1
71	Feed safety clutch end plate	2CK-J74	3CK-J74	1
72	Feed safety clutch gear bushing	2CK-J75	3CK-J75	1
73	Feed safety clutch gear	2CK-J76	3CK-J76	1
74	Spring	2CK-J77	3CK-J77	† 12
75	Feed roller clutch	2CK-J78	3CK-J78	1
76	Feed safety clutch thrust washer	2CK-J79	3CK-J79	1
77	Feed clutch roller cage	2CK-J80	3CK-J80	1
78	Feed roller clutch hub	2CK-J81	3CK-J81	1
79	Clutch plate (Driven)	2CK-J82	3CK-J82	3
80	Clutch plate (Driver)	2CK-J83	3CK-J83	3
81	Brake plate key	2CK-J84	3CK-J84	3
82	Clutch plate retainer	2CK-J85	3CK-J85	1
83	Brake cylinder	2CK-J86	3CK-J86	1
84	Brake piston	2CK-J87	3CK-J87	1
85	Feed safety clutch shaft	2CK-J88	3CK-J88	1
86	Round end key	2CK-J89	3CK-J89	1
87	New Departure brg. 20206	2CK-J90	3CK-J90	1
88	Feed safety clutch shaft brg retainer	2CK-J91	3CK-J91	1
89	Knee	2CK-J92	3CK-J92	1
90	Oval hd screw. 10-32 x 3/8"	2CK-J93	3CK-J93	8
91	Oil sight gage	2CK-J94	3CK-J94	1
92	Oil gage glass	2CK-J95	3CK-J95	1
93	Oil gage washer	2CK-J96	3CK-J96	2
94	Sight oil flow gage	2CK-J97	3CK-J97	1
95	Oil filler screw	2CK-J98	3CK-J98	1
96	Washer	2CK-J99	3CK-J99	1
97	Knee vent plate	2CK-J100	3CK-J100	1
98	Fil hd screw. 1/2-13 x 15/16"	2CK-J101	3CK-J101	† 5
99	Rear control opening cover	2CK-J102	3CK-J102	† 1
100	Expansion plug. 1-1/8" diam.	2CK-J103	3CK-J103	† 1
101	Expansion plug. 7/8"	2CK-J104	3CK-J104	1
102	"O" Ring. 6227-19	2CK-J105	3CK-J105	1
103	Knee clamp shaft spacer	2CK-J106	3CK-J106	1
104	Expansion plug. 1-1/4" diam.	2CK-J107	3CK-J107	2
105	Oil pad	2CK-J108	3CK-J108	1
106	Oil pad	2CK-J109	3CK-J109	1
107	Dog pt set screw. 3/8-16 x 11/16"	2CK-J110		1
107	Dog pt set screw. 3/8-16 x 7/8"		3CK-J110	1
108	Oil seal. Victoprene 60318	2CK-J111	3CK-J111	1
109	Coolant drip spout	2CK-J112	3CK-J112	1
110	Oil flow gage plate	2CK-J113	3CK-J113	1
111	Oil gage indicator plate	2CK-J114	3CK-J114	1
112	Oil seal. Victoprene 60388	2CK-J115		1
112	Oil seal. Victoprene 60562		3CK-J115	1

- * One used on machines with mono-lever control
- † Five used on machines with mono-lever control
- ‡ Two used on machines with mono-lever control
- * Nine springs and 18 balls used on No. 2 machines
- † Used only on machines without rear control
- ‡ Nine springs used on No. 2 machines



WHEN ORDERING PARTS
REPORT SERIAL NUMBER
SHOWN ON THIS PLATE

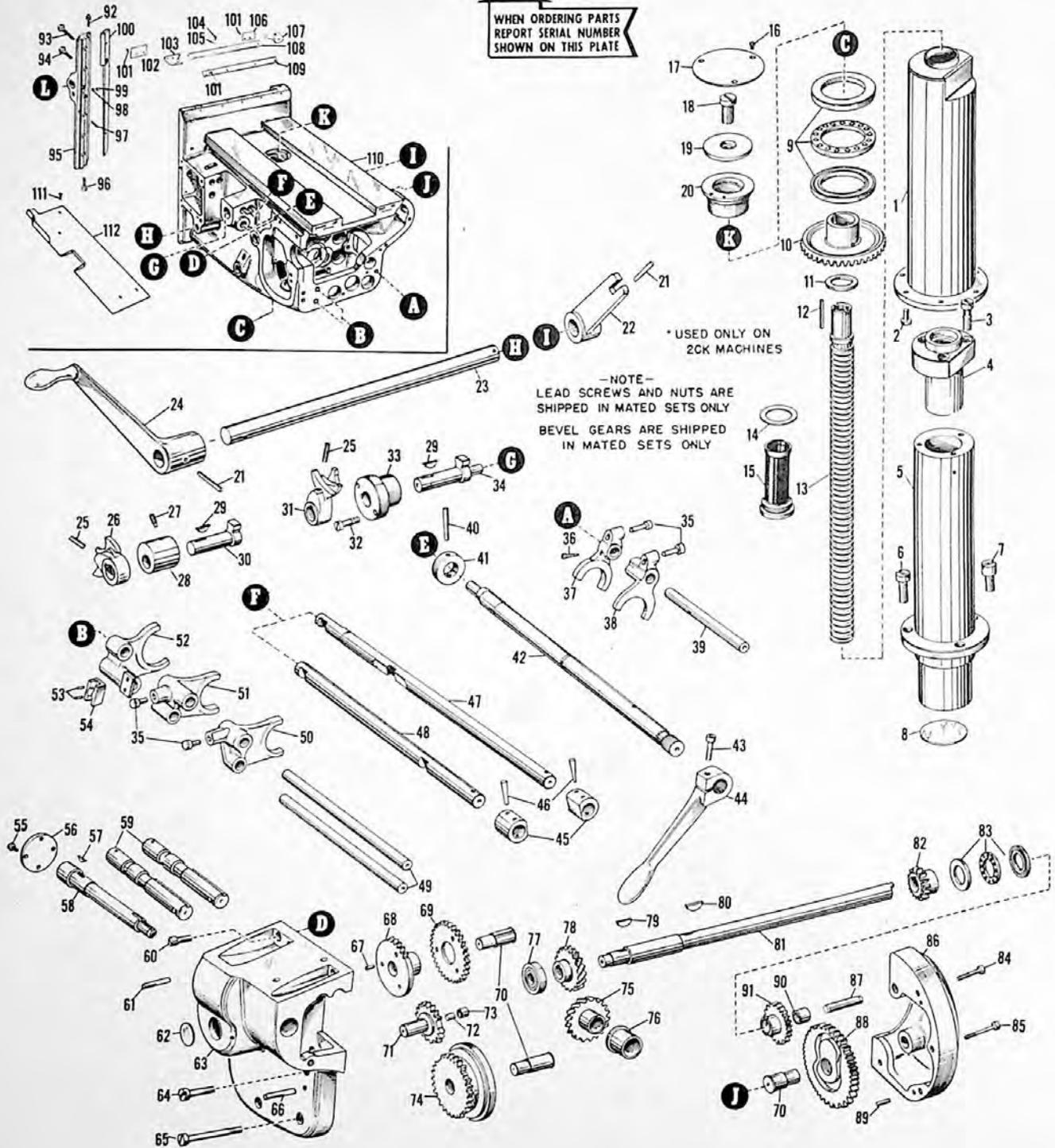

-NOTE-
LEAD SCREWS AND NUTS ARE
SHIPPED IN MATED SETS ONLY
BEVEL GEARS ARE SHIPPED
IN MATED SETS ONLY

* USED ONLY ON
2CK MACHINES

FIG. 14 - KNEE (MISCELLANEOUS PARTS)

Replacement Parts Manual

Milling Machines—Plain, Universal and Vertical

Fig. 14 - Knee (Miscellaneous Parts)

Item No.	Part Name and Description	Code Nos.		Qty.
		2CK	3CK	
1	Elevating screw shield assy	2CK-K1	3CK-K1	1
2	Fil hd screw, 3/8-16 x 13/16"	2CK-K2	3CK-K2	6
3	Fil hd screw, 3/8-16 x 1-3/8"	2CK-K3		3
3	Fil hd screw, 1/2-13 x 1"		3CK-K3	3
4	Elevating screw nut	2CK-K4	3CK-K4	1
5	Elevating nut extension	2CK-K5	3CK-K5	1
6	Fil hd screw, 1/2-13 x 1-1/8"	2CK-K6		2
6	Fil hd screw, 5/8-11 x 1-1/4"		3CK-K6	2
7	Knee bumper screw	2CK-K7	3CK-K7	1
8	Expansion plug, 2-1/2" diam.	2CK-K8		1
8	Expansion plug, 2-5/8" diam.		3CK-K8	1
9	Gurney thrust brg, 13-B	2CK-K9		1
9	Gurney thrust brg, 15-B		3CK-K9	1
10	Elevating bevel gear	2CK-K10	3CK-K10	1
11	Elevating screw collar	2CK-K11		1
12	Key	2CK-K12	3CK-K12	1
13	Elevating screw	2CK-K13	3CK-K13	1
14	Intake screen retaining plug washer	2CK-K14	3CK-K14	1
15	Oil intake screen, retaining plug and ring	2CK-K15	3CK-K15	1
16	Flat hd screw, 8-32 x 1/2"	2CK-K16		3
16	Flat hd screw, 8-32 x 3/8"		3CK-K16	3
17	Elevating bevel gear cover	2CK-K17	3CK-K17	1
18	Fil hd screw, 3/4-16 x 1-3/8"	2CK-K18	3CK-K18	1
19	Elevating screw retainer	2CK-K19	3CK-K19	1
20	Elevating bevel gear brg	2CK-K20	3CK-K20	1
21	Taper pin, #4 x 1-3/4"	2CK-K21	3CK-K21	2
22	Rapid traverse lever shifter arm	2CK-K22	3CK-K22	1
23	Rapid traverse lever shaft	2CK-K23	3CK-K23	1
24	Rapid traverse lever (Rear)	2CK-K24	3CK-K24	1
25	Cup pt sock set screw, 5/16 - 18 x 1"	2CK-K25	3CK-K25	2
26	Vert feed trip lever	2CK-K26	3CK-K26	1
27	Dog pt screw, 3/8-16 x 13/16"	2CK-K27	3CK-K27	1
28	Vert feed trip lever shaft bushing	2CK-K28	3CK-K28	1
29	Hi-pro key, HP-708	2CK-K29	3CK-K29	2
30	Vert feed trip lever arm shaft	2CK-K30	3CK-K30	1
31	Cross feed trip lever	2CK-K31	3CK-K31	1
32	Fil hd screw, 1/4-20 x 1-1/16"	2CK-K32	3CK-K32	2
33	Cross feed lever shaft bushing	2CK-K33	3CK-K33	1
34	Cross feed trip lever arm shaft	2CK-K34	3CK-K34	1
35	Feed shifting fork pin	2CK-K35	3CK-K35	4
36	Taper pin set screw	2CK-K36	3CK-K36	1
37	Primary shaft low speed shifter	2CK-K37	3CK-K37	1
38	Primary shaft high speed shifter	2CK-K38	3CK-K38	1
39	Primary shifter rod	2CK-K39	3CK-K39	1
40	Taper pin, #4 x 1-7/8"	2CK-K40	3CK-K40	1
41	Knee clamp shaft collar	2CK-K41	3CK-K41	1
42	Knee clamp shaft	2CK-K42	3CK-K42	1
43	Fil hd screw, 3/8-16 x 1-1/4"	2CK-K43	3CK-K43	1
44	Knee clamp lever	2CK-K44	3CK-K44	1
45	Trip rod coupling	2CK-K45	3CK-K45	2
46	Taper pin, #4 x 1-7/16"	2CK-K46	3CK-K46	2
47	Vert feed trip rod	2CK-K47	3CK-K47	1
48	Cross feed trip rod	2CK-K48	3CK-K48	1
49	Tertiary shaft shifting rod	2CK-K49	3CK-K49	2
50	Tertiary shaft high speed shifter	2CK-K50	3CK-K50	1
51	Tertiary shaft low speed shifter	2CK-K51	3CK-K51	1
52	Back gear shifter	2CK-K52	3CK-K52	1
53	Pin, 3/16 x 1"	2CK-K53	3CK-K53	2
54	Back gear shifter cam	2CK-K54	3CK-K54	1
55	Fil hd screw, 1/4-20 x 1/2"	2CK-K55	3CK-K55	4
56	Feed change shaft thrust plate	2CK-K56	3CK-K56	1
57	Hi-pro key, HP-606	2CK-K57	3CK-K57	1
58	Feed change shaft	2CK-K58	3CK-K58	1
59	Feed change housing trip rod	2CK-K59	3CK-K59	2

Item No.	Part Name and Description	Code Nos.		Qty.
		2CK	3CK	
60	Fil hd screw, 7/16-14 x 1"	2CK-K60	3CK-K60	2
61	Acme Blue Label dowel, 3/8 x 1-1/4"			
62	Expansion plug, 1-3/8" diam.	2CK-K61	3CK-K61	1
63	Feed change gear housing	2CK-K62	3CK-K62	1
64	Fil hd screw, 1/2-13 x 1-3/4"	2CK-K63	3CK-K63	1
65	Fil hd screw, 1/2-13 x 2-1/2"	2CK-K64	3CK-K64	1
65	Fil hd screw, 1/2-13 x 3-5/8"		2CK-K65	4
66	Acme Blue Label dowel, 3/8 x 1-3/4"			
67	Section hd rivet, #5 x 7/8"	2CK-K66	3CK-K66	1
68	Secondary change intermittent gear	2CK-K67	3CK-K67	3
69	Intermittent gear driver	2CK-K68	3CK-K68	1
70	Shifting cam stud	2CK-K69	3CK-K69	1
71	Back gear shifter cam	2CK-K70	3CK-K70	3
72	Acme Blue Label dowel, 5/16 x 7/8"	2CK-K71	3CK-K71	1
73	Back gear shifter roller	2CK-K72	3CK-K72	1
74	Secondary shifter cam	2CK-K73	3CK-K73	1
75	Feed change helical gear (Driver)	2CK-K74	3CK-K74	1
76	Feed change helical gear brg	2CK-K75	3CK-K75	1
77	New Departure brg, 3203	2CK-K76	3CK-K76	1
78	Feed change helical gear (Driven)	2CK-K77	3CK-K77	1
79	Hi-pro key, HP-705	2CK-K78	3CK-K78	1
80	Hi-pro key, HP-806	2CK-K79	3CK-K79	1
81	Feed change cross shaft	2CK-K80	3CK-K80	1
82	Secondary shifter cam driving gear	2CK-K81	3CK-K81	1
83	Ball thrust brg	2CK-K82	3CK-K82	1
84	Socket cap screw, 3/8 x 1-3/4"	2CK-K83	3CK-K83	1
84	Socket cap screw, 3/8 x 1-1/2"	2CK-K84		3
85	Socket cap screw, 3/8 x 2-1/2"		3CK-K84	3
86	Feed selection cam housing	2CK-K85	3CK-K85	1
87	Primary shifter cam driving gear stud	2CK-K86	3CK-K86	1
88	Primary shifter cam	2CK-K87	3CK-K87	1
89	Acme Blue Label dowel, 1/4 x 2"	2CK-K88	3CK-K88	1
89	Acme Blue Label dowel, 1/4 x 1-1/2"	2CK-K89		2
90	Primary shifter cam driving gear bushing		3CK-K89	2
91	Primary shifter cam driving gear	2CK-K90	3CK-K90	1
92	Gib screw	2CK-K91	3CK-K91	1
93	Hex hd screw, 5/8-11 x 2-1/2"	2CK-K92	3CK-K92	1
93	Hex hd screw, 5/8-11 x 2-3/4"	2CK-K93		2
94	Hex hd screw, 5/8-11 x 2-5/16"		3CK-K93	2
95	Knee gib support	2CK-K94	3CK-K94	4
96	Fil hd screw, 1/2-13 x 1-1/2"	2CK-K95	3CK-K95	1
97	Acme Blue Label dowel, 3/8 x 1-1/2"	2CK-K96	3CK-K96	1
98	Knee clamp shoe	2CK-K97	3CK-K97	1
99	Knee clamp pin	2CK-K98	3CK-K98	1
100	Knee gib	2CK-K99	3CK-K99	1
101	Rd hd mach screw, 10-32 x 3/8"	2CK-K100	3CK-K100	1
102	Column dovetail wiper spring (LH)	2CK-K101	3CK-K101	8
103	Column dovetail wiper (LH)	2CK-K102	3CK-K102	1
104	Wiper screw	2CK-K103	3CK-K103	1
105	Wiper screw spring	2CK-K104	3CK-K104	*7
106	Column dovetail wiper spring (RH)	2CK-K105	3CK-K105	*7
107	Column dovetail wiper (RH)	2CK-K106	3CK-K106	1
108	Column face brg wiper	2CK-K107	3CK-K107	1
109	Column face brg wiper spring	2CK-K108	3CK-K108	1
110	Knee	2CK-K109	3CK-K109	1
111	Flat hd mach screw, 1/4-20 x 1/2"	2CK-K110	3CK-K110	1
112	Knee chip guard	2CK-K111	3CK-K111	4
		2CK-K112	3CK-K112	1

* Nine used on No. 3 machines



WHEN ORDERING PARTS
REPORT SERIAL NUMBER
SHOWN ON THIS PLATE

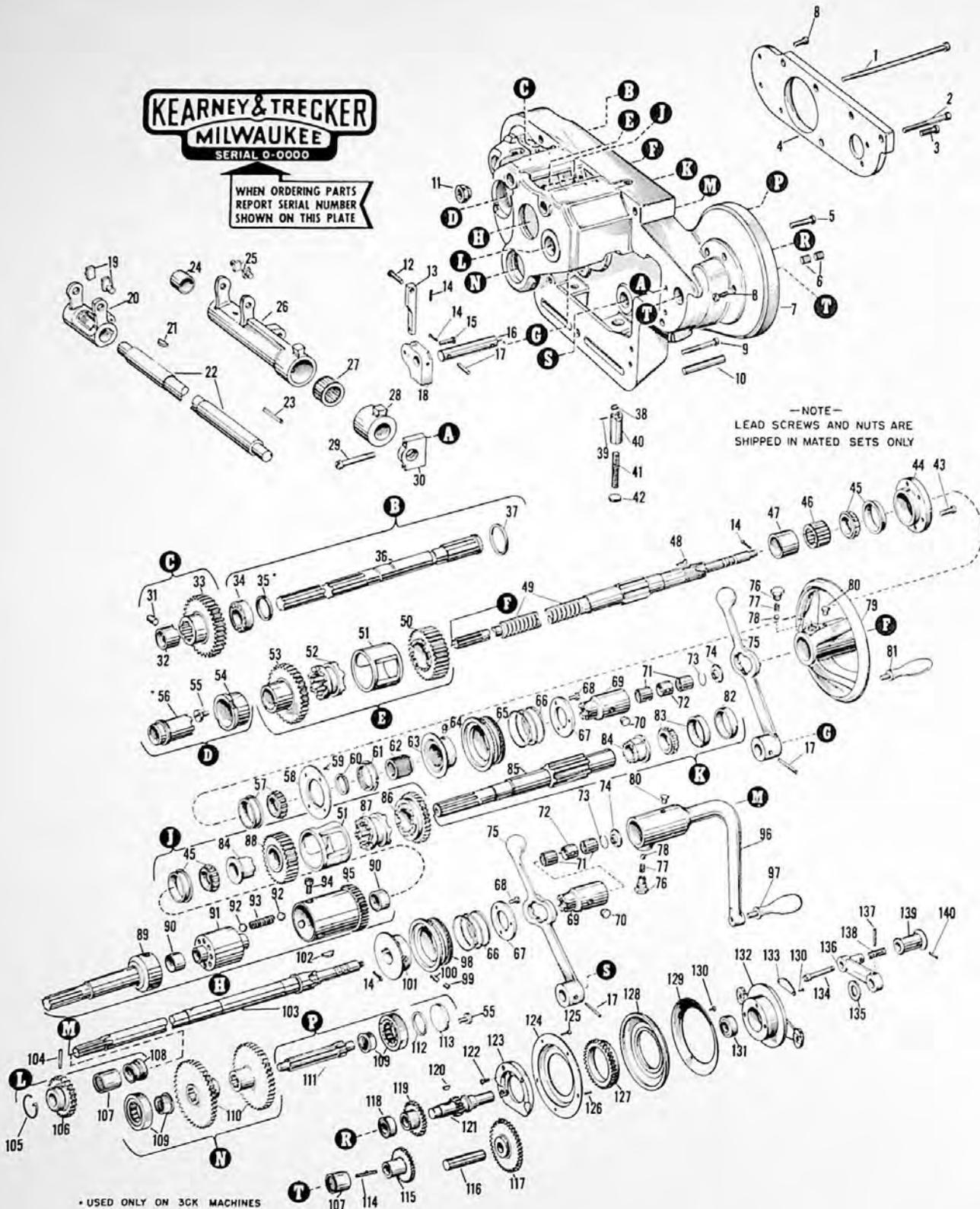

FIG. 15 - FEED DISTRIBUTION BOX

Replacement Parts Manual

Milling Machines—Plain, Universal and Vertical

Fig. 15 - Feed Distribution Box

Item No.	Part Name and Description	Code Nos.		Qty.
		2CK	3CK	
1	Socket cap screw, 1/2-13 x 8-1/4"	2CK-L1	3CK-L1	2
2	Socket cap screw, 1/2 x 3-1/4"	2CK-L2	3CK-L2	2
3	Flt hd screw, 3/8-16 x 21/32"	2CK-L3	3CK-L3	2
4	Feed distribution box dial plate	2CK-L4	3CK-L4	1
5	Socket cap screw, 1/2 x 1-3/4"	2CK-L5	3CK-L5	1
6	Special socket set screw	2CK-L6	3CK-L6	4
7	Feed distribution box	2CK-L7	3CK-L7	1
8	Flt hd screw, 3/8-16 x 7/8"	2CK-L8	3CK-L8	8
9	Socket cap screw, 1/2 x 2-3/4"	2CK-L9	3CK-L9	5
10	Acme Blue Label dowel, 1/2 x 3"	2CK-L10	3CK-L10	2
11	Spacing plug	2CK-L11	3CK-L11	2
12	Reverse lever link pin (Upper)	2CK-L12	3CK-L12	2
13	Reverse lever link	2CK-L13	3CK-L13	2
14	Cotter pin, 2/32 x 3/4"	2CK-L14	3CK-L14	6
15	Reverse lever link pin (Lower)	2CK-L15	3CK-L15	2
16	Cross and elevating reverse lever shaft	2CK-L16	3CK-L16	2
17	Taper pin, #4 x 1-7/8"	2CK-L17	3CK-L17	2
18	Cross feed and elevating inner lever detent	2CK-L18	3CK-L18	2
19	Cross feed and elevating clutch fork shoe	2CK-L19	3CK-L19	2
20	Cross feed clutch fork	2CK-L20	3CK-L20	1
21	Hi-pro key, HP-806	2CK-L21	3CK-L21	1
22	Cross feed clutch fork shaft	2CK-L22	3CK-L22	1
23	Key	2CK-L23	3CK-L23	1
24	Elevating clutch fork and trip segment bushing	2CK-L24	3CK-L24	1
25	Cross feed and elevating clutch fork shoe	2CK-L25	3CK-L25	2
26	Elevating clutch fork and trip segment	2CK-L26	3CK-L26	1
27	Hyatt brg, 94620	2CK-L27	3CK-L27	1
28	Cross feed trip segment	2CK-L28	3CK-L28	1
29	Clutch fork shaft brg screw	2CK-L29	3CK-L29	2
30	Clutch fork shaft brg	2CK-L30	3CK-L30	1
31	Pin, 5/16 x 9/16"	2CK-L31	3CK-L31	1
32	Table feed shaft brg	2CK-L32	3CK-L32	1
33	Table feed shaft drive gear	2CK-L33	3CK-L33	1
34	New Departure brg, 1207	2CK-L34	3CK-L34	1
35	Collar		3CK-L35	1
36	Table feed shaft	2CK-L36	3CK-L36	1
37	Table feed shaft brg spacer	2CK-L37	3CK-L37	1
38	Detent plunger roller	2CK-L38	3CK-L38	2
39	Detent roller pin	2CK-L39	3CK-L39	2
40	Trip detent plunger	2CK-L40	3CK-L40	2
41	Spring	2CK-L41	3CK-L41	2
42	Detent lever plug	2CK-L42	3CK-L42	2
43	Socket cap screw, 5/16 x 3/4"	2CK-L43	3CK-L43	6
44	Cross feed screw brg carrier	2CK-L44	3CK-L44	1
45	Timken brg, 17244B-17119	2CK-L45	3CK-L45	2
46	Torrington brg, B-2420	2CK-L46		1
46	Orange roller brg, 7294		3CK-L46	1
47	Roller brg carrier	2CK-L47	3CK-L47	1
48	Key	2CK-L48	3CK-L48	1
49	Cross feed screw	2CK-L49	3CK-L49	1
50	Cross feed clutch gear (Front)	2CK-L50	3CK-L50	1
51	Clutch gear spacer	2CK-L51	3CK-L51	2
52	Cross feed reverse clutch	2CK-L52	3CK-L52	1
53	Cross feed clutch gear (Rear)	2CK-L53	3CK-L53	1
54	Cross feed clutch gear brg	2CK-L54	3CK-L54	1
55	Flt hd screw, 3/8-16 x 9/16"	2CK-L55	3CK-L55	4
56	Cross feed reverse clutch gear sleeve		3CK-L56	1
57	Timken brg, 17244B-17119W	2CK-L57	3CK-L57	1
58	Cross feed screw oil retainer	2CK-L58	3CK-L58	1
59	Flat hd screw, 8-32 x 3/4"	2CK-L59	3CK-L59	4
60	Cross feed screw brg adj washer	2CK-L60	3CK-L60	1
61	Cross feed screw brg adj ring	2CK-L61	3CK-L61	1
62	Cross feed screw brg adj nut	2CK-L62	3CK-L62	1
63	Cross feed dial collar	2CK-L63	3CK-L63	1
64	Dowel pt screw, 5/16-18 x 1/2"	2CK-L64	3CK-L64	1
65	Serrated graduated dial (250 Divisions)	2CK-L65	3CK-L65	1
66	Spring	2CK-L66	3CK-L66	2
67	Graduated dial spring retainer	2CK-L67	3CK-L67	2

* Eight used on No. 3 machines

Item No.	Part Name and Description	Code Nos.		Qty.
		2CK	3CK	
68	Flt hd screw, 10-32 x 1/2"	2CK-L68	3CK-L68	6
69	Handwheel clutch	2CK-L69	3CK-L69	2
70	Plug	2CK-L70	3CK-L70	2
71	Torrington brg, B-1210	2CK-L71	3CK-L71	4
72	Brg spacer	2CK-L72	3CK-L72	2
73	Snap ring	2CK-L73	3CK-L73	2
74	Hand feed clutch stop	2CK-L74	3CK-L74	2
75	Cross and elevating reverse lever	2CK-L75	3CK-L75	2
76	Hand elevating crank set screw	2CK-L76	3CK-L76	2
77	Spring	2CK-L77	3CK-L77	2
78	Steel ball, 1/4" diam.	2CK-L78	3CK-L78	2
79	Cross feed hand-wheel	2CK-L79	3CK-L79	1
80	Gits oiler, RS-532	2CK-L80	3CK-L80	2
81	Rockwood handle, #3QA	2CK-L81	3CK-L81	1
82	Elevating clutch shaft brg spacer	2CK-L82	3CK-L82	1
83	Timken brg, 17244-17119	2CK-L83	3CK-L83	1
84	Elevating clutch gear bushing	2CK-L84	3CK-L84	2
85	Elevating clutch shaft	2CK-L85	3CK-L85	1
86	Elevating clutch gear (Front)	2CK-L86	3CK-L86	1
87	Elevating reverse clutch	2CK-L87	3CK-L87	1
88	Elevating clutch gear (Rear)	2CK-L88	3CK-L88	1
89	Elevating slip clutch shaft	2CK-L89	3CK-L89	1
90	Elevating slip clutch hub bushing	2CK-L90	3CK-L90	2
91	Elevating slip clutch hub	2CK-L91	3CK-L91	† 1
92	Steel ball, 9/16" diam.	2CK-L92	3CK-L92	12
93	Spring	2CK-L93	3CK-L93	*6
94	Socket cap screw, 3/8-24 x 3/8"	2CK-L94	3CK-L94	3
95	Elevating slip clutch sleeve	2CK-L95	3CK-L95	1
96	Hand elevating crank	2CK-L96	3CK-L96	1
97	Rockwood handle, #4QA	2CK-L97	3CK-L97	1
98	Serrated graduated dial (100 Divisions)	2CK-L98	3CK-L98	1
99	Socket set screw, 1/4 x 1/4"	2CK-L99	3CK-L99	1
100	Socket dog pt screw, 1/4 x 5/16"	2CK-L100	3CK-L100	1
101	Elevating shaft dial collar	2CK-L101	3CK-L101	1
102	Hi-pro key, HP-505	2CK-L102	3CK-L102	1
103	Hand elevating shaft	2CK-L103	3CK-L103	1
104	Taper pin, #4 x 1-9/16"	2CK-L104	3CK-L104	1
105	Snap ring	2CK-L105	3CK-L105	1
106	Hand elevating gear	2CK-L106	3CK-L106	1
107	Torrington brg, B-1616	2CK-L107	3CK-L107	2
108	Elevating shaft brg (Front)	2CK-L108	3CK-L108	1
109	Hyatt brg, R-1305 T.S.	2CK-L109	3CK-L109	2
110	Cross and elevating reverse gear	2CK-L110	3CK-L110	2
111	Cross and elevating reverse gear shaft	2CK-L111	3CK-L111	1
112	Brg washer	2CK-L112	3CK-L112	1
113	Reverse gear shaft brg cover	2CK-L113	3CK-L113	1
114	Key	2CK-L114	3CK-L114	1
115	Feed selection gear (Driven)	2CK-L115	3CK-L115	1
116	Acme Blue Label dowel, 7/16 x 1-3/4"		3CK-L116	1
117	Feed dial idler gear	2CK-L117	3CK-L117	1
118	New Departure brg, 3203	2CK-L118	3CK-L118	1
119	Feed selection gear (Driver)	2CK-L119	3CK-L119	1
120	Hi-pro key, HP-404	2CK-L120	3CK-L120	1
121	Feed dial pinion shaft	2CK-L121	3CK-L121	1
122	Flt hd screw, 5/16-18 x 9/16"	2CK-L122	3CK-L122	3
123	Dial support ring	2CK-L123	3CK-L123	1
124	Grease shield	2CK-L124	3CK-L124	1
125	Flat hd screw, 8-32 x 3/8"	2CK-L125	3CK-L125	5
126	Pin	2CK-L126	3CK-L126	2
127	Feed dial carrier gear	2CK-L127	3CK-L127	1
128	Feed dial carrier	2CK-L128	3CK-L128	1
129	Feed dial (3/8-90 Feed range)	2CK-L129	3CK-L129	1
130	Escutcheon pin, #15	2CK-L130	3CK-L130	18
131	New Departure brg, 88503	2CK-L131	3CK-L131	1
132	Feed dial support bracket	2CK-L132	3CK-L132	1
133	Feed indicator plate	2CK-L133	3CK-L133	1
134	Lever plunger	2CK-L134	3CK-L134	1
135	Dial support washer	2CK-L135	3CK-L135	1
136	Feed dial lever	2CK-L136	3CK-L136	1
137	Taper pin, #3 x 1-5/8"	2CK-L137	3CK-L137	1
138	Spring	2CK-L138	3CK-L138	1
139	Lever knob	2CK-L139	3CK-L139	1
140	Taper pin, #2 x 1"	2CK-L140	3CK-L140	1

† Eighteen used on No. 3 machines

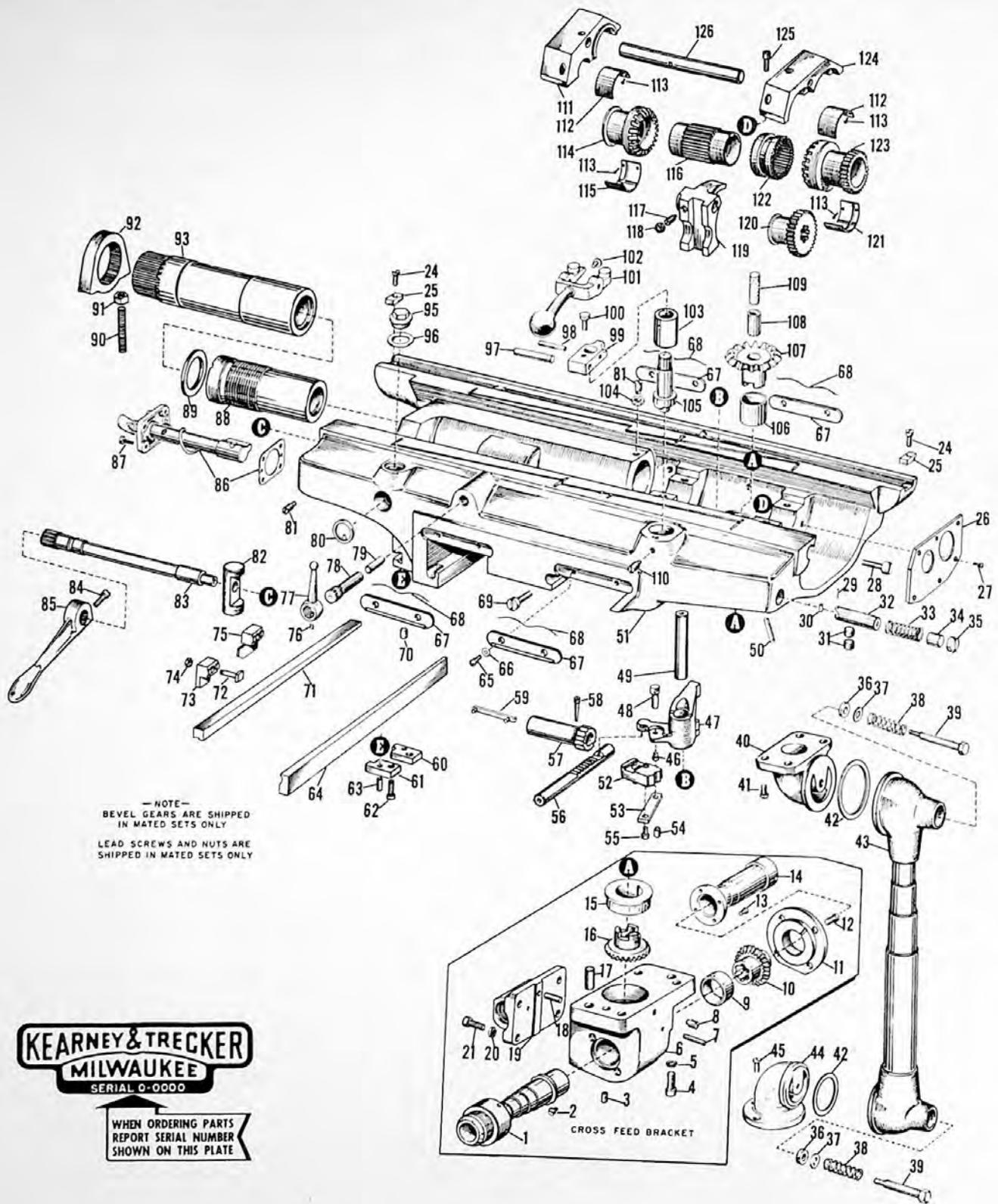

FIG. 16 - PLAIN SADDLE AND CROSS FEED BRACKET

KEARNEY & TRECKER
MILWAUKEE
 SERIAL O-0000

WHEN ORDERING PARTS
 REPORT SERIAL NUMBER
 SHOWN ON THIS PLATE

Replacement Parts Manual

Milling Machines—Plain, Universal and Vertical

Fig. 16 - Plain Saddle and Cross Feed Bracket

Item No.	Part Name and Description	Code Nos.		Qty.
		2CK	3CK	
1	Telescopic tube assy (Front)	2CK-M1	3CK-M1	1
2	Fil hd screw, 5/16-18 x 5/8"	2CK-M2	3CK-M2	2
3	Coolant drip spout	2CK-M3	3CK-M3	1
4	Sock hd cap screw, 1/2 x 1-1/4"	2CK-M4	3CK-M4	4
5	Lockwasher, 1/2"	2CK-M5	3CK-M5	4
6	Cross feed bracket (Standard table control)	2CK-M6	3CK-M6	1
7	Pin, 1/4 x 1-3/8"	2CK-M7		1
7	Pin, 3/16 x 1/8"		3CK-M7	1
8	Dog pt set screw, 3/8-16 x 7/8"	2CK-M8	3CK-M8	1
9	Table feed sliding bevel gear	2CK-M9	3CK-M9	1
10	Table feed sliding bevel gear	2CK-M10	3CK-M10	1
11	Table feed sliding bevel gear brg	2CK-M11	3CK-M11	1
12	Fil hd screw, 3/8-16 x 13/16"	2CK-M12	3CK-M12	4
13	Fil hd screw, 10-32 x 5/16"	2CK-M13	3CK-M13	4
14	Telescopic tube assy (Rear)	2CK-M14	3CK-M14	1
15	Cross feed bracket brg sleeve	2CK-M15	3CK-M15	1
16	Table feed drive bevel gear	2CK-M16	3CK-M16	1
17	Acme Blue Label dowel, 5/8 x 1-1/2"	2CK-M17		2
17	Acme Blue Label dowel, 5/8 x 1-5/8"		3CK-M17	2
18	Acme Blue Label dowel, 3/8 x 7/8"	2CK-M18		1
18	Acme Blue Label dowel, 3/8 x 1"		3CK-M18	1
19	Cross feed nut	2CK-M19	3CK-M19	1
20	Lockwasher, 7/16"	2CK-M20	3CK-M20	4
21	Hex hd cap screw, 7/16-14 x 1-1/8"	2CK-M21		4
21	Sock hd cap screw, 7/16 x 1"		3CK-M21	4
24	Fil hd screw, 5/16-18 x 9/16"	2CK-M24	3CK-M24	2
25	Coolant pocket block	2CK-M25	3CK-M25	2
26	Auxiliary drive shaft gear cover	2CK-M26	3CK-M26	1
27	Rd hd mach screw, 10-32 x 3/8"	2CK-M27	3CK-M27	5
28	Gib screw	2CK-M28	3CK-M28	2
29	Detent roller pin	2CK-M29	3CK-M29	1
30	Detent plunger roller	2CK-M30	3CK-M30	1
31	Special set screw	2CK-M31	3CK-M31	2
32	Table trip detent plunger	2CK-M32	3CK-M32	1
33	Spring	2CK-M33	3CK-M33	1
34	Spring spacer	2CK-M34	3CK-M34	1
35	Plunger hole plug	2CK-M35	3CK-M35	1
36	Coolant fitting washer	2CK-M36	3CK-M36	2
37	Washer, 5/8"	2CK-M37	3CK-M37	2
38	Spring	2CK-M38	3CK-M38	2
39	Coolant fitting stud	2CK-M39	3CK-M39	2
40	Saddle coolant return elbow	2CK-M40	3CK-M40	1
41	Fil hd screw, 3/8-16 x 13/16"	2CK-M41	3CK-M41	4
42	Coolant fitting washer	2CK-M42	3CK-M42	2
43	Coolant return tube assy	2CK-M43	3CK-M43	1
44	Coolant return elbow	2CK-M44	3CK-M44	1
45	Fil hd screw, 1/2-13 x 15/16"	2CK-M45	3CK-M45	3
46	Link pin	2CK-M46	3CK-M46	1
47	Reverse shifter yoke arm	2CK-M47	3CK-M47	1
48	Reverse shifter yoke arm stop pin	2CK-M48	3CK-M48	1
49	Clutch shifter arm stud	2CK-M49	3CK-M49	1
50	Pin	2CK-M50	3CK-M50	1
51	Saddle	2CK-M51	3CK-M51	1
52	Table trip lever detent	2CK-M52	3CK-M52	1
53	Table trip lever link	2CK-M53	3CK-M53	1
54	Reverse link support pin	2CK-M54	3CK-M54	1
55	Link pin (Long)	2CK-M55	3CK-M55	1
56	Release shaft gear rack	2CK-M56	3CK-M56	1
57	Handwheel release shaft gear	2CK-M57	3CK-M57	1
58	Dowel set screw	2CK-M58	3CK-M58	1
59	Key	2CK-M59	3CK-M59	1
60	Limit stop (LH)	2CK-M60	3CK-M60	1
61	Limit stop (RH)	2CK-M61	3CK-M61	1
62	Fil hd screw, 3/8-16 x 21/32"	2CK-M62	3CK-M62	2
63	Acme Blue Label dowel, 5/16 x 3/4"	2CK-M63	3CK-M83	2

Item No.	Part Name and Description	Code Nos.		Qty.
		2CK	3CK	
64	Saddle gib	2CK-M64	3CK-M64	1
65	Wiper spring screw	2CK-M65	3CK-M65	8
66	Wiper spring	2CK-M66	3CK-M66	8
67	Knee top brg wiper	2CK-M67	3CK-M67	4
68	Spring	2CK-M68	3CK-M68	4
69	Gib screw	2CK-M69	3CK-M69	4
70	Pipe plug, 3/4"	2CK-M70		1
70	Sock pipe plug, 1/2"		3CK-M70	1
71	Saddle gib	2CK-M71	3CK-M71	1
72	T-Bolt	2CK-M72	3CK-M72	2
73	Trip dog (RH)	2CK-M73	3CK-M73	1
74	Hex nut, 7/16-14"	2CK-M74	3CK-M74	2
75	Trip dog (LH)	2CK-M75	3CK-M75	1
76	Sock set screw, 1/4-20 x 1/4"	2CK-M76	3CK-M76	1
77	Clamp lever	2CK-M77	3CK-M77	1
78	Clamp screw	2CK-M78	3CK-M78	1
79	Table clamp plug	2CK-M79	3CK-M79	1
80	Bijur oil window, B-4904	2CK-M80	3CK-M80	1
81	Dog pt set screw, 3/8-16 x 7/8"	2CK-M81	3CK-M81	2
82	Saddle clamp	2CK-M82	3CK-M82	1
83	Saddle clamp eccentric	2CK-M83	3CK-M83	1
84	Fil hd screw, 3/8-16 x 7/8"	2CK-M84	3CK-M84	1
85	Saddle clamp handle	2CK-M85	3CK-M85	1
86	Bijur KIB lubricator pump, (1" stroke) C-1957	2CK-M86	3CK-M86	1
87	Sock hd cap screw, 1/4 x 3/4"	2CK-M87	3CK-M87	4
88	Table screw nut	2CK-M88	3CK-M88	1
89	Spacing washer	2CK-M89	3CK-M89	2
90	Oval pt sock set screw, 1/2 x 2-3/4"	2CK-M90	3CK-M90	2
91	Hex nut, 1/2-13"	2CK-M91	3CK-M91	2
92	Adj nut yoke	2CK-M92	3CK-M92	1
93	Adj table screw nut	2CK-M93	3CK-M93	1
95	Oil filler plug	2CK-M95	3CK-M95	1
96	Fibre washer	2CK-M96	3CK-M96	1
97	Acme Blue Label dowel, 3/8 x 3"	2CK-M97	3CK-M97	1
98	Taper pin, #5 x 1-3/8"	2CK-M98	3CK-M98	1
99	Table trip lever block	2CK-M99	3CK-M99	1
100	Table trip block screw	2CK-M100	3CK-M100	1
101	Table trip lever	2CK-M101	3CK-M101	1
102	Table trip lever fork pin	2CK-M102	3CK-M102	1
103	Table trip lever shaft bushing	2CK-M103	3CK-M103	1
104	Hex nut, 3/8-16"	2CK-M104	3CK-M104	1
105	Table trip lever shaft	2CK-M105	3CK-M105	1
106	Table drive gear brg	2CK-M106	3CK-M106	1
107	Table drive gear	2CK-M107	3CK-M107	1
108	Table drive gear plug	2CK-M108	3CK-M108	1
109	Table drive gear felt	2CK-M109	3CK-M109	1
110	Dog pt set screw, 3/8-16 x 3/4"	2CK-M110		1
110	Dog pt set screw, 3/8-16 x 15/16"		3CK-M110	1
111	Brg cap (LH)	2CK-M111	3CK-M111	1
112	Feed reverse gear brg (Upper)	2CK-M112	3CK-M112	2
113	Flat hd brass screw, 8-32 x 1/2"	2CK-M113	3CK-M113	16
114	Table screw clutch gear (LH)	2CK-M114	3CK-M114	1
115	Feed reverse gear brg. (Lower LH)	2CK-M115	3CK-M115	1
116	Table screw sleeve	2CK-M116	3CK-M116	1
117	Dog pt set screw, 3/8-16 x 13/16"	2CK-M117		1
118	Table feed reverse clutch	2CK-M118	3CK-M118	1
119	Clutch shifter yoke	2CK-M119	3CK-M119	1
120	Auxiliary drive shaft gear	2CK-M120	3CK-M120	1
121	Feed reverse gear brg. (Lower RH)	2CK-M121	3CK-M121	1
122	Table feed reverse clutch	2CK-M122	3CK-M122	1
123	Table screw clutch gear (RH)	2CK-M123	3CK-M123	1
124	Brg cap (RH)	2CL-M124	3CK-M124	1
125	Sock cap screw, 3/8 x 1-1/4"	2CK-M125		2
125	Sock cap screw, 3/8 x 7/8"	2CK-M126		2
125	Sock cap screw, 7/16 x 7/8"	2CK-M127		2
125	Sock cap screw, 7/16 x 1"		3CK-M128	4
125	Sock cap screw, 7/16 x 1-3/8"		3CK-M129	2
126	Clutch shifter yoke rod	2CK-M130	3CK-M130	1

Replacement Parts Manual

10hp No. 2 and 15hp No. 3 Model CK

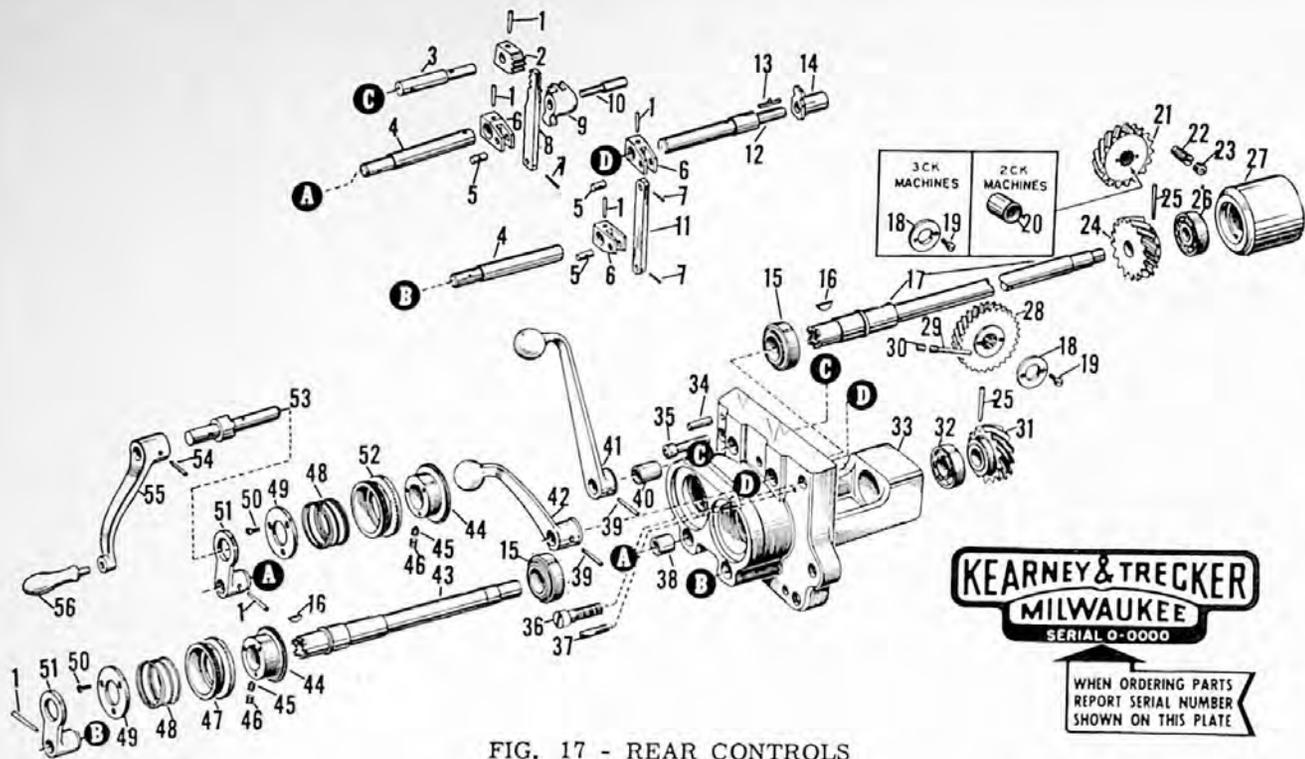

FIG. 17 - REAR CONTROLS

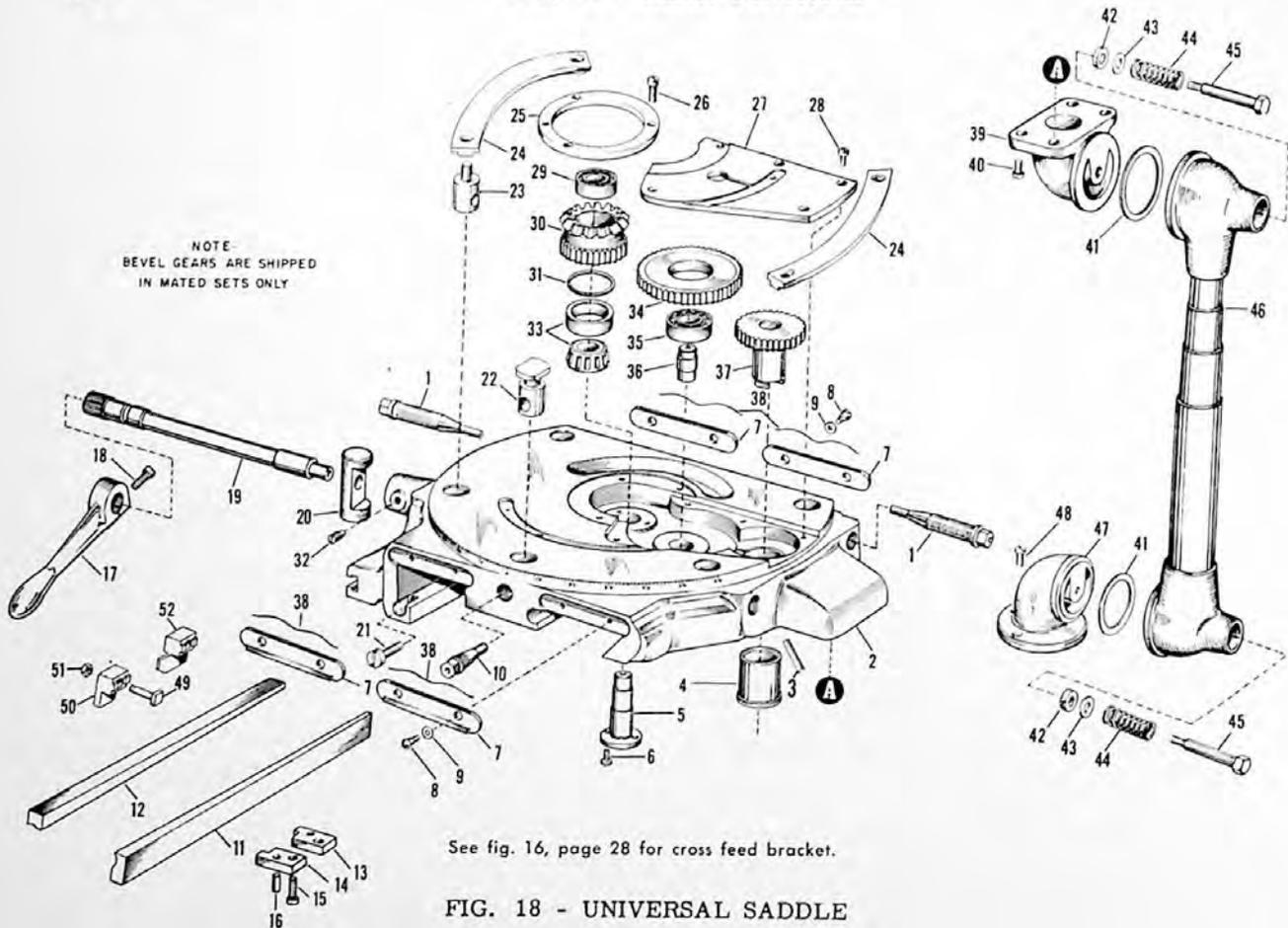

FIG. 18 - UNIVERSAL SADDLE

Replacement Parts Manual

Milling Machines—Plain, Universal and Vertical

Fig. 17- Rear Controls On Knee

Item No.	Part Name and Description	Code Nos.		Qty.	Item No.	Part Name and Description	Code Nos.		Qty.
		2CK	3CK				2CK	3CK	
1	Taper pin, #3 x 1-1/8"	2CK-N1	3CK-N1	6	28	Vert rear control spiral gear (Driven)			
2	Cross feed rear control lever segment	2CK-N2	3CK-N2	1	29	Socket set screw, 3/8 x 3/8"	2CK-N28	3CK-N28	1
3	Cross feed rear control lever shaft	2CK-N3	3CK-N3	1	29	Set screw, 3/8 x 1/2"	2CK-N29		1
4	Crank guard shaft	2CK-N4	3CK-N4	2	30	Dowel screw		3CK-N29	1
5	Clevis pin	2CK-N5	3CK-N5	3	31	Vert rear control spiral gear (Driver)	2CK-N30	3CK-N30	1
6	Clevis joint	2CK-N6	3CK-N6	3	32	New Departure brg. 3205	2CK-N31	3CK-N31	1
7	Cotter pin, 3/32 x 1"	2CK-N7	3CK-N7	3	33	Rear control bracket	2CK-N32	3CK-N32	1
8	Clevis joint rack	2CK-N8	3CK-N8	1	34	Acme Blue Label dowel, 1/2 x 2"	2CK-N33	3CK-N33	1
9	Cross feed trip rod segment	2CK-N9	3CK-N9	1	35	Fil hd screw, 1/2 x 1-11/16"	2CK-N34	3CK-N34	2
10	Cross feed trip rod segment shaft	2CK-N10	3CK-N10	1	36	Fil hd screw, 1/2-13 x 1-1/2"	2CK-N35	3CK-N35	4
11	Link	2CK-N11	3CK-N11	1	37	Socket set screw, 3/8 x 1-1/4"	2CK-N36	3CK-N36	1
12	Vert feed rear control lever shaft	2CK-N12	3CK-N12	1	38	Oilite brg. A-1049-3	2CK-N37	3CK-N37	2
13	Key	2CK-N13	3CK-N13	1	39	Taper pin, #4 x 1-5/16"	2CK-N38	3CK-N38	4
14	Vert feed lever shaft arm	2CK-N14	3CK-N14	1	40	Oilite brg. A-1049-4	2CK-N39	3CK-N39	2
15	New Departure brg. 88506	2CK-N15	3CK-N15	2	41	Cross feed rear control lever	2CK-N40	3CK-N40	2
16	Hi-pro key, HP-505	2CK-N16	3CK-N16	2	42	Vert feed rear control lever	2CK-N41	3CK-N41	1
17	Cross feed rear control shaft	2CK-N17	3CK-N17	1	43	Vert rear control lever	2CK-N42	3CK-N42	1
18	Spiral gear thrust collar	2CK-N18	3CK-N18	*1	44	Vert rear control shaft	2CK-N43	3CK-N43	1
19	Fil hd screw, 3/16-32 x 3/8"	2CK-N19	3CK-N19	†2	45	Rear control serrated dial collar	2CK-N44	3CK-N44	2
20	Spacer and oil sealed sleeve	2CK-N20		1	46	Socket dog pt screw, 5/16 x 1/4"	2CK-N45	3CK-N45	2
21	Cross feed rear control spiral gear (Driven)	2CK-N21	3CK-N21	1	47	Socket set screw, 5/16 x 1/4"	2CK-N46	3CK-N46	2
22	Dog pt set screw, 3/8-16 x 1-3/16"	2CK-N22		1	48	Vert rear control serrated dial	2CK-N47	3CK-N47	1
22	Dog pt set screw, 1/2-13 x 1-3/8"		3CK-N22	1	49	Spring	2CK-N48	3CK-N48	2
23	Socket set screw, 3/8 x 3/8"	2CK-N23		1	49	Rear control dial spring retainer	2CK-N49	3CK-N49	2
23	Socket set screw, 1/2 x 1/4"		3CK-N23	1	50	Fil hd screw, 10-32 x 1/2"	2CK-N50	3CK-N50	6
24	Cross feed rear control spiral gear (Driver)	2CK-N24	3CK-N24	1	51	Rear control crank guard	2CK-N51	3CK-N51	2
25	Taper pin, #4 x 1-7/8"	2CK-N25	3CK-N25	2	52	Cross feed rear control serrated dial	2CK-N52	3CK-N52	1
26	New Departure brg. 3304	2CK-N26	3CK-N26	1	53	Rear control crank guide pin	2CK-N53	3CK-N53	1
27	Cross feed spiral gear brg carriage	2CK-N27	3CK-N27	1	54	Taper pin, #4 x 1-7/16"	2CK-N54	3CK-N54	1
					55	Rear control cross and elevating crank	2CK-N55	3CK-N55	1
					56	Rockwood handle, 3QA	2CK-N56	3CK-N56	1

* Two used on No. 3 machines

† Four used on No. 3 machines

Fig. 18 - Universal Saddle

Item No.	Part Name and Description	Code Nos.		Qty.	Item No.	Part Name and Description	Code Nos.		Qty.
		2CK	3CK				2CK	3CK	
1	Swivel block clamp screw	2CK-P1	3CK-P1	4	28	Fil hd screw, 5/16-18 x 11/16"	2CK-P28	3CK-P28	4
2	Universal saddle	2CK-P2	3CK-P2	1	29	New Departure brg. #1204	2CK-P29		1
3	Pin	2CK-P3	3CK-P3	1	29	New Departure brg. #3205		3CK-P29	1
4	Table drive gear brg	2CK-P4	3CK-P4	1	30	Table drive bevel gear	2CK-P30	3CK-P30	1
5	Table drive bevel gear stud	2CK-P5	3CK-P5	1	31	Bevel gear adj washer	2CK-P31	3CK-P31	1
6	Fil hd screw, 5/16-18 x 9/16"	2CK-P6	3CK-P6	2	32	Dog pt set screw, 3/8-16 x 13/16"	2CK-P32		1
7	Knee top brg wiper	2CK-P7	3CK-P7	4	32	Dog pt set screw, 3/8-16 x 7/8"		3CK-P32	1
8	Wiper screw	2CK-P8	3CK-P8	8	33	Timken brg. #1779-1729	2CK-P33		1
9	Spring	2CK-P9	3CK-P9	8	33	Timken brg. #26126-26274		3CK-P33	1
10	Swivel block clamp screw	2CK-P10	3CK-P10	1	34	Table drive idler gear	2CK-P34	3CK-P34	1
11	Saddle gib	2CK-P11	3CK-P11	1	35	New Departure brg. #1205	2CK-P35		1
12	Saddle gib	2CK-P12	3CK-P12	1	35	New Departure brg. #1207		3CK-P35	1
13	Limit stop (LH)	2CK-P13	3CK-P13	1	36	Idler gear stud	2CK-P36	3CK-P36	1
14	Limit stop (RH)	2CK-P14	3CK-P14	1	37	Table drive gear	2CK-P37	3CK-P37	1
15	Fil hd screw, 3/8-16 x 21/32"	2CK-P15	3CK-P15	2	38	Spring	2CK-P38	3CK-P38	4
16	Acme Blue Label dowel, 5/16 x 3/4"	2CK-P16	3CK-P16	2	39	Saddle coolant return elbow	2CK-P39	3CK-P39	1
17	Saddle clamp handle	2CK-P17	3CK-P17	1	40	Fil hd screw, 3/8-16 x 13/16"	2CK-P40	3CK-P40	4
18	Fil hd screw, 3/8-16 x 7/8"	2CK-P18	3CK-P18	1	41	Coolant fitting washer (leather)	2CK-P41	3CK-P41	2
19	Saddle clamp eccentric	2CK-P19	3CK-P19	1	42	Coolant fitting washer (felt)	2CK-P42	3CK-P42	2
20	Saddle clamp	2CK-P20	3CK-P20	1	43	Washer, 5/8"	2CK-P43	3CK-P43	2
21	Gib screw	2CK-P21	3CK-P21	4	44	Spring	2CK-P44	3CK-P44	2
22	Swivel block clamp	2CK-P22	3CK-P22	1	45	Coolant fitting stud	2CK-P45	3CK-P45	2
23	Swivel block clamp bolt	2CK-P23	3CK-P23	4	46	Coolant return tube assy	2CK-P46	3CK-P46	1
24	Swivel block clamp ring	2CK-P24	3CK-P24	2	47	Coolant return elbow	2CK-P47	3CK-P47	1
25	Ring in saddle	2CK-P25	3CK-P25	1	48	Fil hd screw, 1/2-13 x 15/16"	2CK-P48	3CK-P48	3
26	Fil hd screw, 5/16-18 x 11/16"	2CK-P26		3	49	T-Bolt	2CK-P49	3CK-P49	2
26	Fil hd screw, 3/8-16 x 7/8"		3CK-P26	3	50	Trip dog (RH)	2CK-P50	3CK-P50	1
27	Universal saddle cover	2CK-P27	3CK-P27	1	51	Hex nut, 7/16-14	2CK-P51	3CK-P51	2
					52	Trip dog (LH)	2CK-P52	3CK-P52	1



WHEN ORDERING PARTS
REPORT SERIAL NUMBER
SHOWN ON THIS PLATE

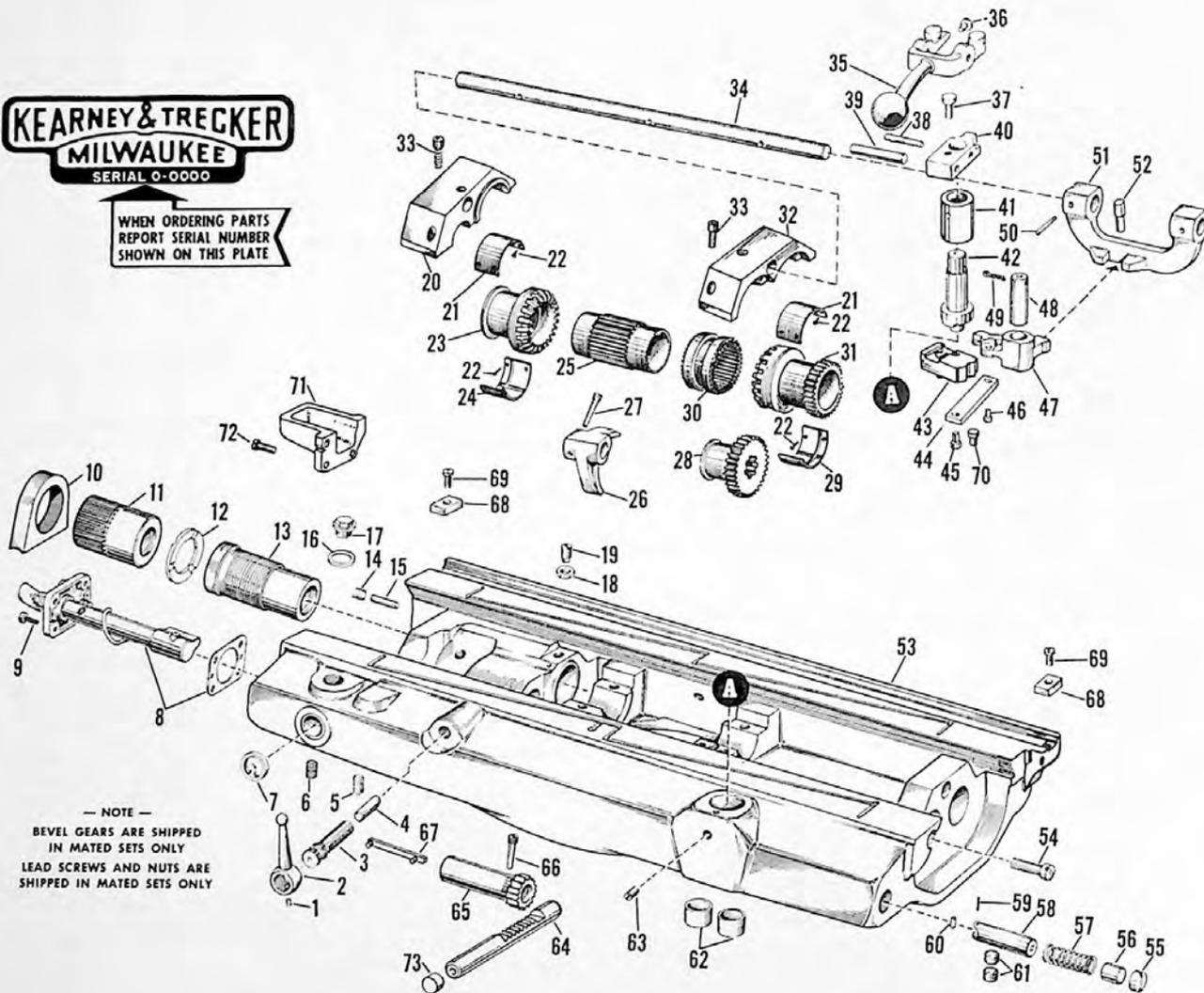

FIG. 19 - UNIVERSAL SWIVEL BLOCK

Replacement Parts Manual

Milling Machines—Plain, Universal and Vertical

Fig. 19 - Universal Swivel Block

Item No.	Part Name and Description	Code Nos.		Qty.	Item No.	Part Name and Description	Code Nos.		Qty.
		2CK	3CK				2CK	3CK	
1	Socket set screw, 1/4 x 1/4"	2CK-Q1	3CK-Q1	1	34	Clutch shifter yoke rod	2CK-Q38	3CK-Q38	1
2	Clamp lever	2CK-Q2	3CK-Q2	1	35	Table trip lever	2CK-Q39	3CK-Q39	1
3	Clamp screw	2CK-Q3	3CK-Q3	1	36	Table trip lever fork pin	2CK-Q40	3CK-Q40	1
4	Clamp plug	2CK-Q4	3CK-Q4	1	37	Table trip lever block screw	2CK-Q41	3CK-Q41	1
5	Socket set screw, oval pt, 1/2-13 x 1-3/8"	2CK-Q5		2	38	Taper pin, #5 x 1-3/4"	2CK-Q42	3CK-Q42	1
5	Socket set screw, oval pt, 1/2-13 x 1-3/4"		3CK-Q5	2	39	Acme Blue Label dowel, 3/8 x 3"	2CK-Q43	3CK-Q43	1
6	Pipe plug, 3/4"	2CK-Q6		1	40	Table trip lever block	2CK-Q44	3CK-Q44	1
6	Pipe plug, 1/2"		3CK-Q6	1	41	Table trip lever shaft bushing	2CK-Q45	3CK-Q45	1
7	Bijur oil window, B-5093	2CK-Q7	3CK-Q7	1	42	Table trip lever shaft	2CK-Q46	3CK-Q46	1
8	Bijur KIB lubricator pump, C-1957 (1 stroke)	2CK-Q8	3CK-Q8	1	43	Table trip lever detent	2CK-Q47	3CK-Q47	1
9	Socket hd cap screw, 1/4-20 x 3/4"	2CK-Q9	3CK-Q9	4	44	Table trip lever link	2CK-Q48	3CK-Q48	1
10	Adj nut yoke	2CK-Q10	3CK-Q10	1	45	Link pin (Long)	2CK-Q49	3CK-Q49	1
11	Adjustable table screw nut	2CK-Q11	3CK-Q11	1	46	Link pin	2CK-Q50	3CK-Q50	1
12	Spacing washer	2CK-Q12	3CK-Q12	1	47	Reverse shifter yoke arm	2CK-Q51	3CK-Q51	1
13	Table screw nut	2CK-Q13	3CK-Q13	1	48	Clutch shifter arm stud	2CK-Q52	3CK-Q52	1
14	Socket set screw, flat pt, 3/8-16 x 3/4"	2CK-Q14	3CK-Q14	2	49	Cotter pin, 1/8 x 1"	2CK-Q53	3CK-Q53	1
15	Yoke lock screw plug	2CK-Q15	3CK-Q15	2	50	Taper pin, #4 x 1-3/8"	2CK-Q54		2
16	Fibre washer	2CK-Q16	3CK-Q16	1	50	Taper pin, #4 x 1-1/4"		3CK-Q54	2
17	Oil hole plug	2CK-Q17	3CK-Q17	1	51	Reverse shifter yoke	2CK-Q55	3CK-Q55	1
18	Hex nut, 3/8-16"	2CK-Q18	3CK-Q18	1	52	Shifter yoke stop pin	2CK-Q56	3CK-Q56	1
19	Dog pt set screw, 3/8-16 x 7/8"	2CK-Q19		1	53	Universal Swivel block	2CK-Q57	3CK-Q57	1
19	Dog pt set screw, 3/8-16 x 11/16"		3CK-Q19	1	54	Gib screw	2CK-Q58	3CK-Q58	2
20	Brg cap (LH)	2CK-Q20	3CK-Q20	1	55	Detent plunger plug	2CK-Q59	3CK-Q59	1
21	Feed reverse gear brg (Upper)	2CK-Q21	3CK-Q21	2	56	Spring spacer	2CK-Q60	3CK-Q60	1
22	Flat hd brass screw, 8-32 x 1/2"	2CK-Q22	3CK-Q22	4	57	Spring	2CK-Q61	3CK-Q61	1
23	Table screw clutch gear (LH)	2CK-Q23	3CK-Q23	1	58	Table trip detent plunger	2CK-Q62	3CK-Q62	1
24	Feed reverse gear brg (Lower LH)	2CK-Q24	3CK-Q24	1	59	Detent roller pin	2CK-Q63	3CK-Q63	1
25	Table screw sleeve	2CK-Q25	3CK-Q25	1	60	Detent roller	2CK-Q64	3CK-Q64	1
26	Clutch shifter	2CK-Q26	3CK-Q26	1	61	Special set screw	2CK-Q65	3CK-Q65	2
27	Taper pin screw	2CK-Q27	3CK-Q27	1	62	Coolant return tube	2CK-Q66	3CK-Q66	2
28	Auxiliary drive shaft gear	2CK-Q28	3CK-Q28	1	63	Dog pt set screw, 3/8-16 x 13/16"	2CK-Q67		1
29	Feed reverse gear brg (Lower RH)	2CK-Q29	3CK-Q29	1	63	Dog pt set screw, 3/8-16 x 15/16"		3CK-Q67	1
30	Table feed reverse clutch	2CK-Q30	3CK-Q30	1	64	Release shaft gear rack	2CK-Q68	3CK-Q68	1
31	Table screw clutch gear (RH)	2CK-Q31	3CK-Q31	1	65	Handwheel release shaft gear	2CK-Q69	3CK-Q69	1
32	Brg cap (RH)	2CK-Q32	3CK-Q32	1	66	Dowel set screw	2CK-Q70	3CK-Q70	1
33	Socket hd cap screw, 3/8 x 1-1/4"	2CK-Q33		2	67	Key	2CK-Q71	3CK-Q71	1
33	Socket hd cap screw, 3/8 x 7/8"	2CK-Q34		2	68	Coolant pocket block	2CK-Q72	3CK-Q72	2
33	Socket hd cap screw, 7/16 x 7/8"	2CK-Q35		2	69	Fil hd screw, 5/16-18 x 9/16"	2CK-Q73	3CK-Q73	2
33	Socket hd cap screw, 7/16 x 1"		3CK-Q36	4	70	Link support pin	2CK-Q74	3CK-Q74	1
33	Socket hd cap screw, 7/16 x 1-1/4"		3CK-Q37	2	71	Saddle Extension	2CK-Q75		1
					71	Saddle Extension		3CK-Q75	1
					72	Fil hd screw, 7/16 x 11/16"	2CK-Q76		3
					72	Fil hd screw, 7/16 x 1"		3CK-Q76	3
					73	Plug, 7/8 x 1/2"	2CK-Q77	3CK-Q77	1

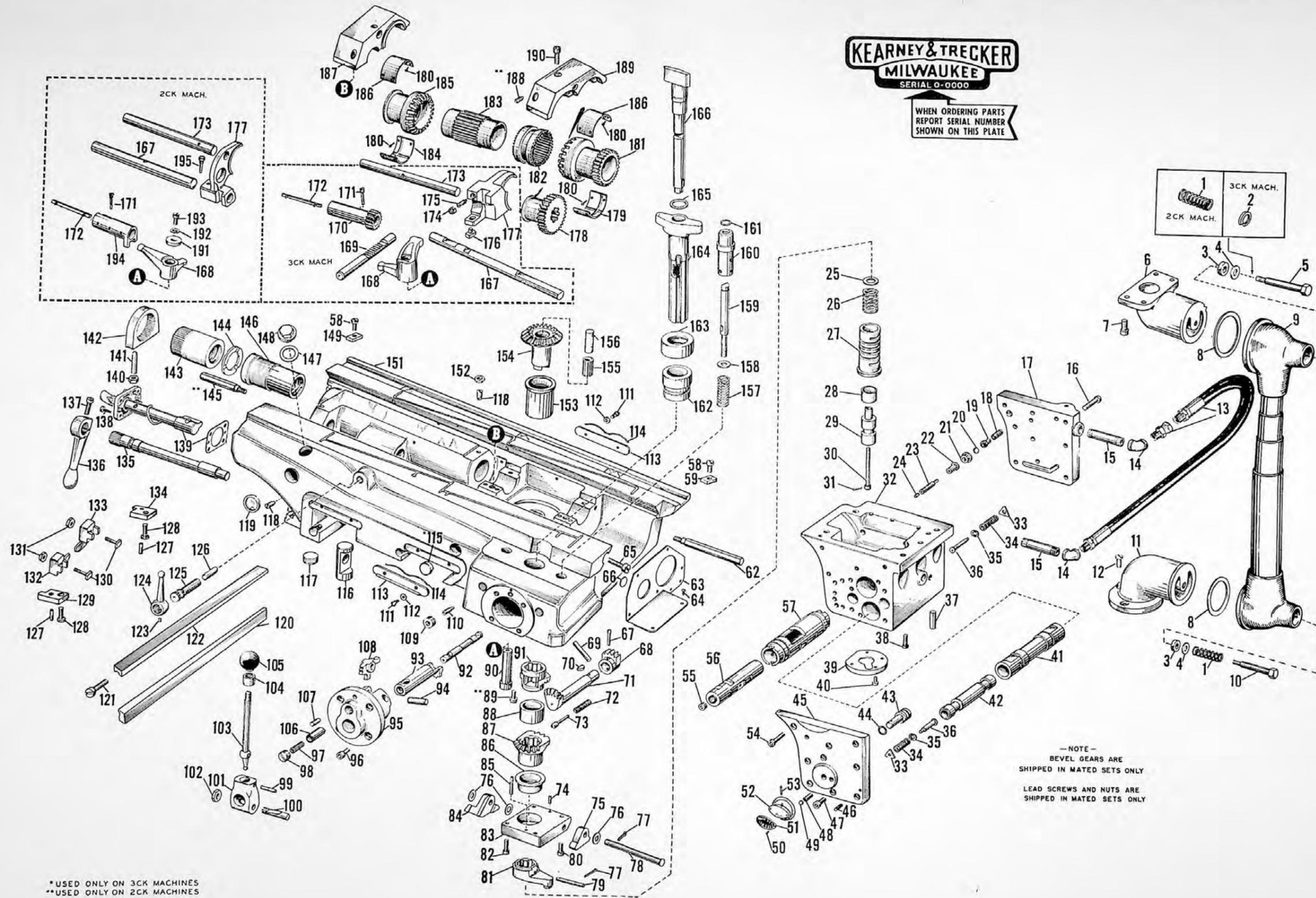

*USED ONLY ON 3CK MACHINES
**USED ONLY ON 2CK MACHINES

FIG. 20 - AUTOMATIC CYCLE SADDLE & HYDRAULIC VALVE BODY

Fig. 20 - Automatic Cycle Saddle & Hydraulic Valve Body

Item No.	Part Name and Description	Code Nos.		Qty.
		2CK	3CK	
Hydraulic Valve Body and Coolant Return				
1	Spring	2CK-R1	3CK-R1	*2
2	Lockwasher, 5/8"		3CK-R2	1
3	Coolant fitting washer	2CK-R3	3CK-R3	2
4	Washer	2CK-R4	3CK-R4	2
5	Coolant fitting stud	2CK-R5	3CK-R5	1
6	Saddle coolant return elbow	2CK-R6	3CK-R6	1
7	Fil hd screw, 3/8-16 x 13/16"	2CK-R7	3CK-R7	4
8	Coolant fitting washer	2CK-R8	3CK-R8	2
9	Telescopic coolant return tube assy	2CK-R9	3CK-R9	1
10	Coolant fitting stud	2CK-R10	3CK-R10	1
11	Column coolant return elbow	2CK-R11	3CK-R11	1
12	Fil hd screw, 1/2-13 x 15/16"	2CK-R12	3CK-R12	3
13	Ario flexible hose and fitting, 3/8 ID	2CK-R13	3CK-R13	2
14	Elbow, 3/8"	2CK-R14	3CK-R14	4
15	W. I. Nipple, 3/8 x 3-1/4"	2CK-R15	3CK-R15	4
16	Socket hd cap screw, 3/8 x 1-1/2"	2CK-R16	3CK-R16	9
17	Valve body cover, back	2CK-R17	3CK-R17	1
18	Spring	2CK-R18	3CK-R18	2
19	Valve ball guide	2CK-R19	3CK-R19	2
20	Steel ball, 7/16" diam	2CK-R20	3CK-R20	2
21	Valve seat insert	2CK-R21	3CK-R21	2
22	Automatic reverse valve stem bushing	2CK-R22	3CK-R22	2
23	Automatic reverse valve stem	2CK-R23	3CK-R23	2
24	Automatic reverse valve stem plug	2CK-R24	3CK-R24	2
25	Rate piston spring washer	2CK-R25	3CK-R25	1
26	Spring	2CK-R26	3CK-R26	1
27	Rate cylinder sleeve	2CK-R27	3CK-R27	1
28	Rate return piston	2CK-R28	3CK-R28	1
29	Rate piston	2CK-R29	3CK-R29	1
30	Rate piston screw	2CK-R30	3CK-R30	1
31	Cotter pin, 1/16 x 1"	2CK-R31	3CK-R31	1
32	Control valve body	2CK-R32	3CK-R32	1
33	Spring retaining collar	2CK-R33	3CK-R33	2
34	Spring	2CK-R34	3CK-R34	2
35	Automatic reverse spring retaining washer	2CK-R35	3CK-R35	2
36	Spring retaining pin	2CK-R36	3CK-R36	2
37	Acme Blue Label dowel, 3/8 x 1-1/4"	2CK-R37	3CK-R37	2
38	Socket hd cap screw, 7/16 x 1-1/4"	2CK-R38	3CK-R38	5
39	Rate cylinder retaining plate	2CK-R39	3CK-R39	1
40	Socket hd cap screw, 1/4 x 5/8"	2CK-R40	3CK-R40	4
41	Automatic reverse valve sleeve	2CK-R41	3CK-R41	1
42	Automatic reverse valve	2CK-R42	3CK-R42	1
43	Manual reverse rate valve	2CK-R43	3CK-R43	1
44	"O" Ring, PRP902-10	2CK-R44	3CK-R44	1
45	Valve body cover, front	2CK-R45	3CK-R45	1
46	Socket hd oval pt set screw, 5/16 x 5/8"	2CK-R46	3CK-R46	2
47	Socket hd cap screw, 3/8 x 3/4"	2CK-R47	3CK-R47	1
48	Spring	2CK-R48	3CK-R48	1
49	Steel ball, 5/16" diam	2CK-R49	3CK-R49	1
50	#15 Escutcheon pin	2CK-R50	3CK-R50	2

Item No.	Part Name and Description	Code Nos.		Qty.
		2CK	3CK	
51	Selector knob plate	2CK-R51	3CK-R51	1
52	Selector knob	2CK-R52	3CK-R52	1
53	Taper pin, #02 x 3/4"	2CK-R53	3CK-R53	1
54	Socket hd cap screw, 3/8 x 1"	2CK-R54	3CK-R54	8
55	Socket hd pipe plug, 1/4"	2CK-R55	3CK-R55	1
56	Table direction piston	2CK-R56	3CK-R56	1
57	Table direction cylinder sleeve	2CK-R57	3CK-R57	1
Automatic Cycle Plain Saddle				
58	Fil hd screw, 5/16-18 x 9/16"	2CK-R58	3CK-R58	2
59	Coolant pocket block (R.H.)	2CK-R59	3CK-R59	1
62	Positive stop	2CK-R62	3CK-R62	1
63	Auxiliary drive shaft gear cover	2CK-R63	3CK-R63	1
64	Rh hd mach screw, 10-32 x 3/8"	2CK-R64	3CK-R64	3
65	Gib screw	2CK-R65	3CK-R65	2
66	Expansion plug, 9/16"	2CK-R66	3CK-R66	1
66	Expansion plug, 5/8"		3CK-R66	1
67	Taper pin screw	2CK-R67	3CK-R67	1
68	Table trip lever segment	2CK-R68	3CK-R68	1
69	Pin	2CK-R69	3CK-R69	1
70	Hi-pro key, HP-604	2CK-R70	3CK-R70	1
71	Shifter bevel gear segment	2CK-R71	3CK-R71	1
72	Spring	2CK-R72	3CK-R72	1
73	Detent plunger	2CK-R73	3CK-R73	1
74	Acme Blue Label dowel, 1/4 x 7/8"	2CK-R74	3CK-R74	1
75	Right hand reverse bell crank	2CK-R75	3CK-R75	1
76	Washer	2CK-R76	3CK-R76	3
77	Cotter pin, 3/32 x 7/8"	2CK-R77	3CK-R77	3
78	Bell crank shaft	2CK-R78	3CK-R78	1
79	Automatic reverse lever pin	2CK-R79	3CK-R79	1
80	Socket hd cap screw, 5/16 x 5/8"	2CK-R80	3CK-R80	2
81	Automatic reverse lever	2CK-R81	3CK-R81	1
82	Socket hd cap screw, 5/16 x 7/8"	2CK-R82	3CK-R82	2
83	Bell crank support	2CK-R83	3CK-R83	1
84	Left hand reverse bell crank	2CK-R84	3CK-R84	1
85	Acme Blue Label dowel, 1/4 x 1-1/4"	2CK-R85	3CK-R85	1
86	Bell crank support bushing	2CK-R86	3CK-R86	1
87	Hand trip bevel gear segment	2CK-R87	3CK-R87	1
88	Spacing collar	2CK-R88	3CK-R88	1
89	Socket hd cap screw, 5/16 x 5/8"	2CK-R89	3CK-R89	1
90	Clutch shifter arm stud	2CK-R90	3CK-R90	1
91	Feed trip bevel segment	2CK-R91	3CK-R91	1
92	Feed and rapid traverse shifter rod	2CK-R92	3CK-R92	1
93	Feed and rapid traverse shifter rod sleeve and pinion	2CK-R93	3CK-R93	1
94	Acme Blue Label dowel, 1/2 x 1-5/8"	2CK-R94	3CK-R94	1
95	Feed and rapid traverse lever bracket	2CK-R95	3CK-R95	1
96	Socket hd cap screw, 3/8 x 3/4"	2CK-R96	3CK-R96	4
97	Spring	2CK-R97	3CK-R97	1
98	Plug screw, 3/4-16 x 7/16"	2CK-R98	3CK-R98	1
99	Acme Blue Label dowel, 5/16 x 1-1/2"	2CK-R99	3CK-R99	1
100	Feed and rapid traverse lever hub cotter	2CK-R100	3CK-R100	1

Item No.	Part Name and Description	Code Nos.		Qty.
		2CK	3CK	
101	Feed and rapid traverse lever hub (For machines without low lead attachment)	2CK-R101	3CK-R101	1
101	Feed and rapid traverse lever hub (For machines with low lead attachment)	2CK-R101	3CK-R101	1
102	Hex nut, 1/2-13"	2CK-R102	3CK-R102	1
103	Feed and rapid traverse lever	2CK-R103	3CK-R103	1
104	Feed and rapid traverse lever chip seal	2CK-R104	3CK-R104	1
105	Shifter lever knob	2CK-R105	3CK-R105	1
106	Feed and rapid traverse detent plunger	2CK-R106	3CK-R106	1
107	Acme Blue Label dowel, 3/8 x 7/8"	2CK-R107	3CK-R107	1
108	Feed and rapid traverse bell crank	2CK-R108	3CK-R108	1
109	Socket hd pipe plug, 1/2"	2CK-R109	3CK-R109	2
110	Dowel screw	2CK-R110	3CK-R110	2
111	Wiper screw	2CK-R111	3CK-R111	8
112	Wiper screw spring	2CK-R112	3CK-R112	8
113	Knee top brg wiper	2CK-R113	3CK-R113	4
114	Wiper spring	2CK-R114	3CK-R114	4
115	Saddle plug	3CK-R115		1
116	Saddle clamp	2CK-R116	3CK-R116	1
117	Pipe plug, 3/4"	2CK-R117		1
117	Pipe plug, 1/2"		3CK-R117	1
118	Dog pt set screw, 3/8-16 x 7/8"	2CK-R118	3CK-R118	2
119	Bijur oil window, B-4904	2CK-R119	3CK-R119	1
120	Saddle gib	2CK-R120	3CK-R120	1
121	Gib screw	2CK-R121	3CK-R121	4
122	Saddle gib	2CK-R122	3CK-R122	1
123	Socket set screw, 1/4 x 1/4"	2CK-R123	3CK-R123	1
124	Clamp lever	2CK-R124	3CK-R124	1
125	Clamp screw	2CK-R125	3CK-R125	1
126	Table clamp plug	2CK-R126	3CK-R126	1
127	Acme Blue Label dowel, 5/16 x 3/4"	2CK-R127	3CK-R127	2
128	Fil hd screw, 3/8-16 x 21/32"	2CK-R128	3CK-R128	2
129	Saddle limit stop (Front)	2CK-R129	3CK-R129	1
130	T-Bolt	2CK-R130	3CK-R130	2
131	Hex nut, 7/16-14"	2CK-R131	3CK-R131	2
132	Trip dog (L.H.)	2CK-R132	3CK-R132	1
133	Trip dog (R.H.)	2CK-R133	3CK-R133	1
134	Saddle limit stop (Rear)	2CK-R134	3CK-R134	1
135	Saddle clamp eccentric	2CK-R135	3CK-R135	1
136	Saddle clamp lever	2CK-R136	3CK-R136	1
137	Fil hd screw, 3/8-16 x 7/8"	2CK-R137	3CK-R137	1
138	Socket hd cap screw, 1/4-20 x 3/4"	2CK-R138	3CK-R138	4
139	Bijur KIB lubricator pump (1" stroke), C-1957	2CK-R139	3CK-R139	1
140	Hex nut, 1/2-13"	2CK-R140	3CK-R140	2
141	Rd pt socket set screw, 1/2-13 x 2-1/2"	2CK-R141		2
141	Rd pt socket set screw, 1/2-13 x 3-1/2"		3CK-R141	2
142	Adj nut yoke	2CK-R142	3CK-R142	1
143	Adj table screw nut	2CK-R143	3CK-R143	1
144	Spacer washer	2CK-R144	3CK-R144	1

Item No.	Part Name and Description	Code Nos.		Qty.
		2CK	3CK	
145	Positive stop	2CK-R145		1
146	Table screw nut	2CK-R146	3CK-R146	1
147	Washer	2CK-R147	3CK-R147	1
148	Oil hole plug	2CK-R148	3CK-R148	1
149	Coolant pocket block (L.H.)	2CK-R149	3CK-R149	1
151	Saddle.	2CK-R151	3CK-R151	1
152	Hex nut, 3/8-16	2CK-R152	3CK-R152	1
153	Table drive bevel gear bearing	2CK-R153	3CK-R153	1
154	Table feed drive bevel gear	2CK-R154	3CK-R154	1
155	Table drive gear plug	2CK-R155	3CK-R155	1
156	Table drive gear felt	2CK-R156	3CK-R156	1
157	Spring	2CK-R157	3CK-R157	2
158	Table reverse plunger washer	2CK-R158	3CK-R158	2
159	Reverse plunger	2CK-R159	3CK-R159	2
160	Reverse plunger sleeve	2CK-R160	3CK-R160	2
161	"O" Ring, AN6227-12	2CK-R161	3CK-R161	2
162	Feed trip sleeve brg	2CK-R162	3CK-R162	1
163	Trip sleeve chip guard	2CK-R163	3CK-R163	1
164	Feed trip sleeve	2CK-R164	3CK-R164	1
165	Neoprene packing	2CK-R165	3CK-R165	1
166	Rate change trip post	2CK-R166	3CK-R166	1
167	Clutch shifter rack	2CK-R167	3CK-R167	1
168	Reverse shifter yoke arm	2CK-R168	3CK-R168	1
169	Release shaft gear rack		3CK-R169	1
170	Handwheel release shaft gear		3CK-R170	1
171	Headless dowel screw	2CK-R171	3CK-R171	1
172	Key	2CK-R172	3CK-R172	1
173	Clutch shifter yoke rod	2CK-R173	3CK-R173	1
174	Hex nut, 3/8-16"	2CK-R174	3CK-R174	1
175	Headless dowel screw, 3/8-16 x 1"	2CK-R175	3CK-R175	1
176	Clutch fork trip block	2CK-R176	3CK-R176	1
177	Clutch shifter yoke	2CK-R177	3CK-R177	1
178	Auxiliary drive shaft gear	2CK-R178	3CK-R178	1
179	Feed reverse gear brg (Lower R.H.)	2CK-R179	3CK-R179	1
180	Flat hd brass screw, 8-32 x 1/2"	2CK-R180	3CK-R180	16
181	Table screw clutch gear (R.H.)	2CK-R181	3CK-R181	1
182	Table feed reverse clutch	2CK-R182	3CK-R182	1
183	Table screw sleeve	2CK-R183	3CK-R183	1
184	Feed reverse gear brg (Lower L.H.)	2CK-R184	3CK-R184	1
185	Table screw clutch gear (L.H.)	2CK-R185	3CK-R185	1
186	Feed reverse gear brg (Upper)	2CK-R186	3CK-R186	2
187	Brg cap (L.H.)	2CK-R187	3CK-R187	1
188	Dog pt socket set screw, 3/8 x 1"	2CK-R188		1
189	Brg cap (R.H.)	2CK-R189	3CK-R189	1
190	Socket cap screw, 3/8 x 1-1/4"	2CK-R190		2
190	Socket cap screw, 3/8 x 7/8"	2CK-R191		2
190	Socket cap screw, 7/16 x 7/8"	2CK-R192		2
190	Socket cap screw, 7/16 x 1"		3CK-R193	2
190	Socket cap screw, 7/16 x 1-3/8"		3CK-R194	2
191	Bell crank retainer	2CK-R195		1
192	Lockwasher, 5/16"	2CK-R196		1
193	Fil hd screw, 5/16-18 x 3/4"	2CK-R197		1
194	Handwheel release shaft fork	2CK-R198		1
195	Taper pin screw	2CK-R199		1

*Only one used on No. 3 machines

Replacement Parts Manual

10 hp No. 2 and 15 hp No. 3 Model CK



WHEN ORDERING PARTS
REPORT SERIAL NUMBER
SHOWN ON THIS PLATE

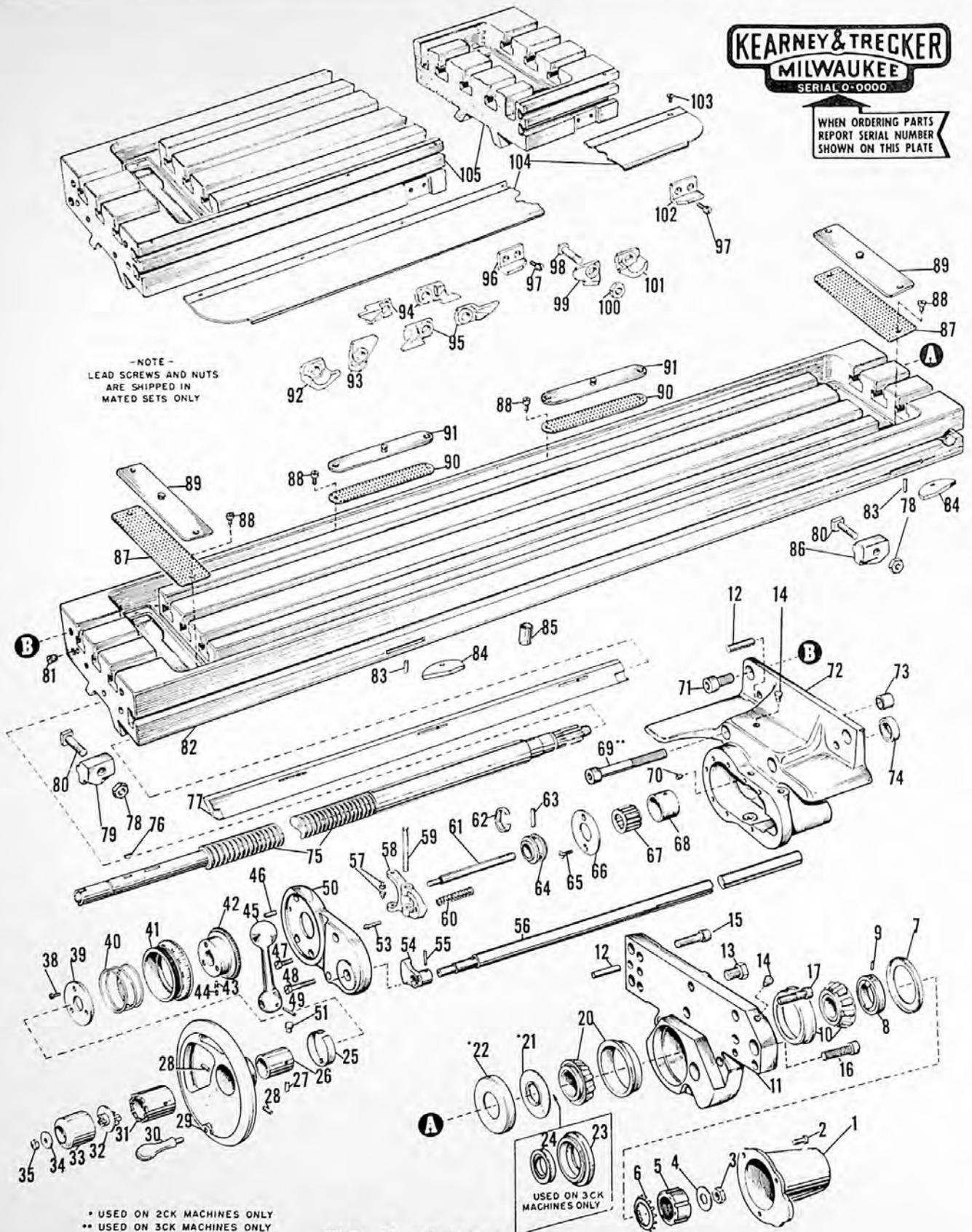

-NOTE -
LEAD SCREWS AND NUTS
ARE SHIPPED IN
MATED SETS ONLY

* USED ON 2CK MACHINES ONLY
** USED ON 3CK MACHINES ONLY

USED ON 3CK
MACHINES ONLY

FIG. 21 - TABLES

BUILDERS OF PRECISION AND PRODUCTION



MACHINE TOOLS FOR MILLING AND BORING

Replacement Parts Manual

Milling Machines—Plain, Universal and Vertical

Fig. 21 - Tables

Item No.	Part Name and description	Code Nos.		Qty.
		2CK	3CK	
1	Table bracket cover (RH)	2CK-S1	3CK-S1	1
2	Fil hd screw, 5/16-18 x 11/16"	2CK-S2		3
2	Fil hd screw, 5/16-18 x 9/16"		3CK-S2	3
3	Hex nut, 1/2-13"	2CK-S3	3CK-S3	1
4	Washer, 1/2"	2CK-S4		1
4	Washer, 1/2"		3CK-S4	1
5	Brg adj nut	2CK-S5	3CK-S5	1
6	Lockwasher, Timken, 3809	2CK-S6		1
6	Lockwasher, #7		3CK-S6	1
7	Brg cover	2CK-S7	3CK-S7	1
8	Brg clutch collar	2CK-S8	3CK-S8	1
9	Pin	2CK-S9		1
9	Pin, 1/4 x 9/16		3CK-S9	1
10	Timken brg, 41286B-41125W	2CK-S10		1
10	Timken brg, 44348B-44143W		3CK-S10	1
11	Table bracket (RH)	2CK-S11	3CK-S11	1
12	Acme Blue Label dowel, 3/8 x 1-1/2"	2CK-S12		4
12	Acme Blue Label dowel, 1/2 x 1-3/4"		3CK-S12	4
13	Table bracket plug	2CK-S13	3CK-S13	1
14	Gits oiler, RS533	2CK-S14	3CK-S14	3
15	Sock hd cap screw, 1/2 x 1-1/2"	2CK-S15		2
15	Sock hd cap screw, 5/8 x 1-1/2"		3CK-S15	3
16	Sock hd cap screw, 7/16-14 x 1-1/2"	2CK-S16		2
16	Sock hd cap screw, 1/2 x 1-1/4"		3CK-S16	1
17	Hex hd cap screw, 1/2-13 x 1-7/8"	2CK-S17		4
17	Hex hd cap screw, 5/8-11 x 1-7/8"		3CK-S17	3
20	Timken brg, 41286B-41125	2CK-S20		1
20	Timken brg, 44348B-44143		3CK-S20	1
21	Grease retainer	2CK-S21		1
22	Brg cover	2CK-S22		1
23	Oil seal carrier		3CK-S23	1
24	Gits oil seal, O.S. 1750		3CK-S24	1
25	Snap ring	2CK-S25	3CK-S25	1
26	Handwheel bushing	2CK-S26	3CK-S26	1
27	Handwheel retaining pin	2CK-S27	3CK-S27	1
28	Pin	2CK-S28	3CK-S28	2
29	Handwheel	2CK-S29	3CK-S29	1
30	Rockwood handle, #3QA	2CK-S30	3CK-S30	1
31	Clutch in handwheel	2CK-S31	3CK-S31	1
32	Handwheel clutch	2CK-S32	3CK-S32	1
33	Handwheel clutch knob	2CK-S33	3CK-S33	1
34	Clutch washer	2CK-S34	3CK-S34	1
35	Hex nut, 5/16-2"	2CK-S35	3CK-S35	1
38	Fil hd screw, 10-32 x 1/2"	2CK-S38	3CK-S38	3
39	Graduated dial spring retainer	2CK-S39	3CK-S39	1
40	Spring	2CK-S40	3CK-S40	1
41	Graduated dial	2CK-S41	3CK-S41	1
42	Serrated dial collar	2CK-S42	3CK-S42	1
43	Dog pt set screw, 1/4-20 x 1/2"	2CK-S43	3CK-S43	1
44	Sock set screw, 1/4-20 x 1/4"	2CK-S44	3CK-S44	1
45	Table reverse lever	2CK-S45	3CK-S45	1
46	Acme Blue Label dowel, 1/4 x 3/4"	2CK-S46	3CK-S46	1
47	Fil hd screw, 5/16-18 x 11/16"	2CK-S47		4
47	Fil hd screw, 5/16-18 x 9/16"		3CK-S47	4
48	Fil hd screw, 5/16-18 x 1-1/4"	2CK-S48	3CK-S48	2
49	Taper pin, #2 x 1-3/8"	2CK-S49	3CK-S49	1
50	Table bracket cover (LH)	2CK-S50	3CK-S50	1
51	Gits oiler, RS532	2CK-S51	3CK-S51	1

Item No.	Part Name and Description	Code Nos.		Qty.
		2CK	3CK	
53	Clutch release yoke pin	2CK-S53	3CK-S53	2
54	Clutch release cam	2CK-S54	3CK-S54	1
55	Taper pin, #2 x 7/8"	2CK-S55	3CK-S55	1
56	Handwheel release shaft	2CK-S56	3CK-S56	1
57	Shifter yoke pin	2CK-S57	3CK-S57	2
58	Clutch release yoke	2CK-S58	3CK-S58	1
59	Clutch release yoke shaft	2CK-S59	3CK-S59	1
60	Spring (Not used in Auto-cycle mach)	2CK-S60	3CK-S60	1
61	Clutch release rod	2CK-S61	3CK-S61	1
62	Snap ring	2CK-S62	3CK-S62	1
63	Clutch release rod pin	2CK-S63	3CK-S63	1
64	Clutch release plate	2CK-S64	3CK-S64	1
65	Flat hd mach screw, 1/4-20 x 5/8"	2CK-S65		2
65	Fil hd screw, 10-32 x 1/2"		3CK-S65	2
66	Hyatt brg retainer	2CK-S66	3CK-S66	1
67	Hyatt brg, 94516	2CK-S67		1
67	Hyatt brg, RA-94720		3CK-S67	1
68	Brg race	2CK-S68	3CK-S68	1
69	Sock cap screw, 5/8 x 5"		3CK-S69	2
70	Cone pt pin	2CK-S70	3CK-S70	1
71	Fil hd screw, 1/2-13 x 1-1/4"	2CK-S71		4
71	Sock hd cap screw, 5/8-11 x 1-1/4"		3CK-S71	2
72	Table bracket (LH)	2CK-S72	3CK-S72	1
72	Table bracket (LH) (No.3 Autocycle)		3CK-S72	1
73	Oilite brg, A-1203	2CK-S73	3CK-S73	1
74	Gits oil seal, O.S.-1000	2CK-S74		1
74	Gits oil seal, O.S.-1250		3CK-S74	1
75	Table screw	2CK-S75	3CK-S75	1
76	Hi-pro key, HP-606	2CK-S76	3CK-S76	1
77	Table gib	2CK-S77	3CK-S77	1
78	Hex nut, 7/16-14"	2CK-S78	3CK-S78	4
79	Table trip dog (LH)	2CK-S79	3CK-S79	2
80	T-Bolt	2CK-S80	3CK-S80	4
81	Pipe plug, 3/4"	2CK-S81	3CK-S81	1
82	Table	2CK-S82	3CK-S82	1
83	Limit stop pin	2CK-S83	3CK-S83	2
84	Limit block	2CK-S84	3CK-S84	1
85	Coolant return tube	2CK-S85	3CK-S85	2
86	Table trip dog (RH)	2CK-S86	3CK-S86	2
87	Table screen (Large)	2CK-S87	3CK-S87	2
88	Fil hd screw, 10-32 x 5/16"	2CK-S88	3CK-S88	8
89	Table screen cover (Large)	2CK-S89	3CK-S89	2
90	Table screen (Small)	2CK-S90	3CK-S90	2
91	Table screen cover (Small)	2CK-S91	3CK-S91	2
92	Reverse dog (LH)	2CK-S92	3CK-S92	1
93	Stop dog (LH)	2CK-S93	3CK-S93	1
94	Rate change dog "B"	2CK-S94	3CK-S94	2
95	Rate change dog "A"	2CK-S95	3CK-S95	2
96	Table limit block (LH)	2CK-S96	3CK-S96	1
97*	Fil hd screw, 5/16-18 x 11/16"	2CK-S97	3CK-S97	4
98*	T-Bolt	2CK-S98	3CK-S98	8
99*	Stop dog (RH)	2CK-S99	3CK-S99	1
100*	Hex nut, 7/16-20"	2CK-S100	3CK-S100	8
101*	Reverse dog (RH)	2CK-S101	3CK-S101	1
102*	Table limit block (RH)	2CK-S102	3CK-S102	1
103*	Flat hd mach screw, 1/4-20 x 1/2"	2CK-S103	3CK-S103	10
104*	Table coolant guard	2CK-S104	3CK-S104	1
105*	Table (Autocycle)	2CK-S105	3CK-S105	1

* For automatic cycle machines only
 ** Eleven used on No. 3 machines

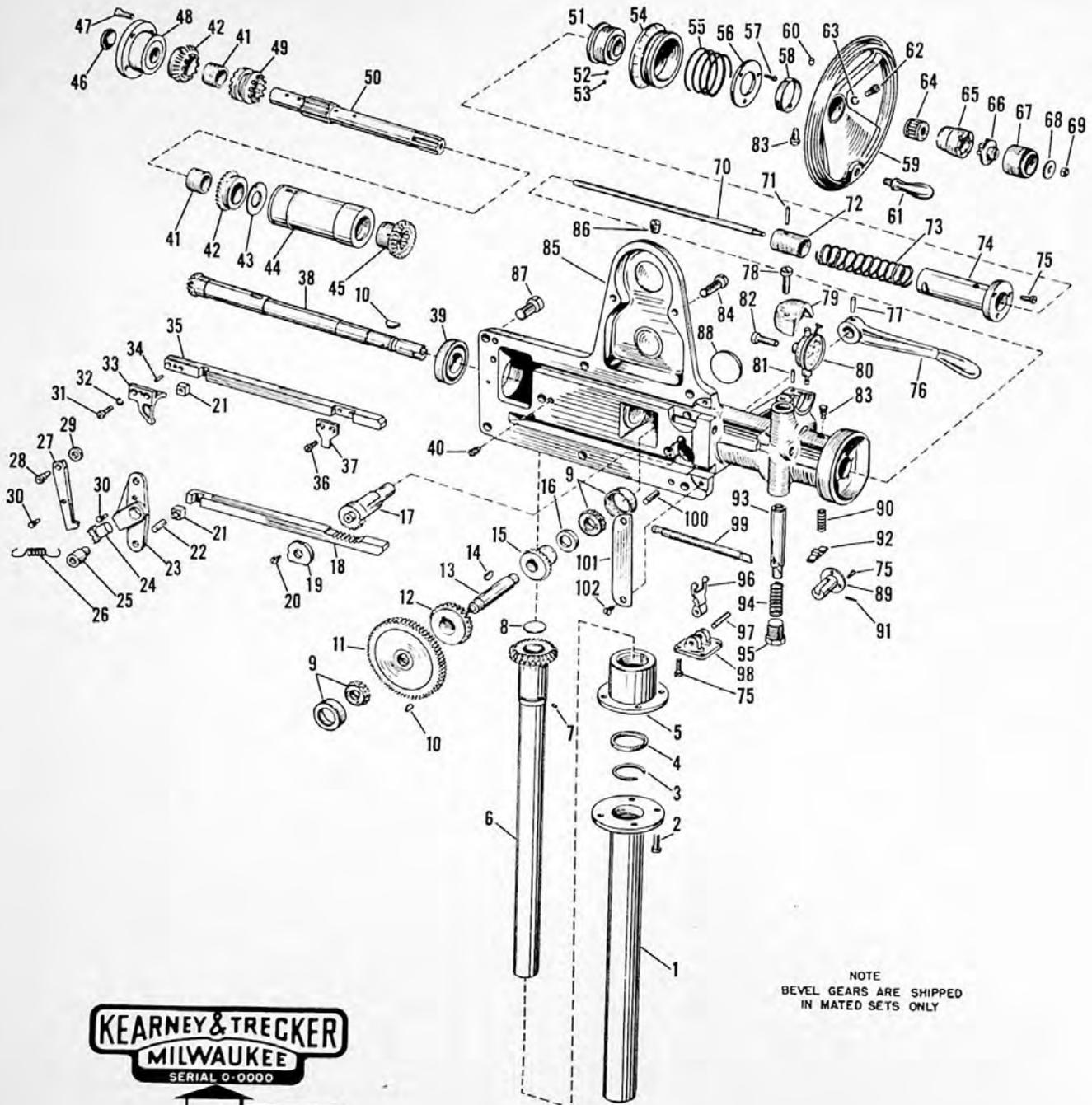

NOTE
BEVEL GEARS ARE SHIPPED
IN MATED SETS ONLY



WHEN ORDERING PARTS
REPORT SERIAL NUMBER
SHOWN ON THIS PLATE

FIG. 22 - HEAD POWER FEED BRACKET

Replacement Parts Manual

Milling Machines—Plain, Universal and Vertical

Fig. 22 - Head Power Feed Bracket

Item No.	Part Name and Description	Code Nos.		Qty.	Item No.	Part Name and Description	Code Nos.		Qty.
		2CK	3CK				2CK	3CK	
1	Inner telescopic tube and flange	2CK-T1	3CK-T1	1	52	Socket screw, 1/4 x 5/16"	2CK-T52	3CK-T52	1
2	Fil hd screw, 3/8-16 x 1-1/16"	2CK-T2	3CK-T2	4	53	Socket set screw, 1/4 x 1/4"	2CK-T53	3CK-T53	1
3	Snap ring	2CK-T3	3CK-T3	1	54	Graduated dial	2CK-T54	3CK-T54	1
4	Hd feed drive gear washer	2CK-T4	3CK-T4	1	55	Spring	2CK-T55	3CK-T55	1
5	Hd feed drive miter gear brg	2CK-T5	3CK-T5	1	56	Graduated dial spring retainer	2CK-T56	3CK-T56	1
6	Hd feed drive miter gear (Upper)	2CK-T6	3CK-T6	1	57	Fil hd screw, 10-32 x 1/2"	2CK-T57	3CK-T57	3
7	Pin, 3/16 x 9/32"	2CK-T7	3CK-T7	1	58	Pin retainer spring	2CK-T58	3CK-T58	1
8	Expansion plug, 1-3/16"	2CK-T8	3CK-T8	1	59	Hd adj handwheel	2CK-T59	3CK-T59	1
9	Timken brg, 07204B-07079	2CK-T9	3CK-T9	2	60	Handwheel retaining pin	2CK-T60	3CK-T60	1
10	Hi-pro key, HP-606	2CK-T10	3CK-T10	2	61	Rockwood handle, 3QA	2CK-T61	3CK-T61	1
11	Hd feed take-off gear	2CK-T11	3CK-T11	1	62	Adj screw	2CK-T62	3CK-T62	1
12	Vert hd feed miter gear	2CK-T12	3CK-T12	1	63	Lockwasher, 5/16"	2CK-T63	3CK-T63	1
13	Feed take-off gear shaft	2CK-T13	3CK-T13	1	64	Hyatt brg, 93416	2CK-T64	3CK-T64	1
14	Hi-pro key, HP-706	2CK-T14	3CK-T14	1	65	Vert hd handwheel clutch	2CK-T65	3CK-T65	1
15	Hd feed take-off bevel gear	2CK-T15	3CK-T15	1	66	Handwheel clutch	2CK-T66	3CK-T66	1
16	Fitting washer	2CK-T16	3CK-T16	7	67	Handwheel clutch knob	2CK-T67	3CK-T67	1
17	Hd feed starting lever eccentric and pinton	2CK-T17	3CK-T17	1	68	Clutch washer	2CK-T68	2CK-T68	1
18	Trip plunger (Lower)	2CK-T18	3CK-T18	1	69	Hex nut, 5/16-24	2CK-T69	3CK-T69	1
19	Starting lever brg	2CK-T19	3CK-T19	1	70	Handwheel release rod	2CK-T70	3CK-T70	1
20	Fil hd screw, 1/4-20 x 1/2"	2CK-T20	3CK-T20	3	71	Handwheel release rod pin	2CK-T71	3CK-T71	1
21	Trip plunger shoe	2CK-T21	3CK-T21	2	72	Vert handwheel release shaft	2CK-T72	3CK-T72	1
22	Acme Blue Label dowel, 3/8 x 1"	2CK-T22	3CK-T22	2	73	Spring	2CK-T73	3CK-T73	1
23	Vert hd feed trip equalizing lever	2CK-T23	3CK-T23	1	74	Handwheel shaft retainer bushing	2CK-T74	3CK-T74	1
24	Vert hd trip detent	2CK-T24	3CK-T24	1	75	Fil hd screw, 1/4-20 x 1/2"	2CK-T75	3CK-T75	10
25	Equalizing lever plug	2CK-T25	3CK-T25	1	76	Hd feed starting lever	2CK-T76	3CK-T76	1
26	Spring	2CK-T26	3CK-T26	1	77	Taper pin, #3 x 1-1/2"	2CK-T77	3CK-T77	1
27	Detent lever	2CK-T27	3CK-T27	1	78	Fil hd screw, 5/16-18 x 1-1/4"	2CK-T78	3CK-T78	2
28	Detent lever stud	2CK-T28	3CK-T28	1	79	Indicator cap	2CK-T79	3CK-T79	1
29	Detent spacer	2CK-T29	3CK-T29	1	80	Starrett Indicator (Standard)	2CK-T80	3CK-T80	1
30	Spring post	2CK-T30	3CK-T30	2	81	Acme Blue Label dowel, 1/4 x 1-3/8"	2CK-T81	3CK-T81	2
31	Fil hd screw, 5/16-18 x 1"	2CK-T31		2	82	Fil hd screw, 1/4-28 x 1"	2CK-T82	3CK-T82	1
32	Allen hd screw, 5/16-18 x 3/4"		3CK-T31	2	83	Gits oiler, RS-532	2CK-T83	3CK-T83	2
33	Lockwasher, 5/16"	2CK-T32	3CK-T32	2	84	Socket cap screw, 3/8 x 1"	2CK-T84	3CK-T84	2
34	Hd feed clutch shifter	2CK-T33	3CK-T33	1	85	Vert hd power feed bracket	2CK-T85	3CK-T85	1
35	Acme Blue Label dowel, 1/4 x 3/4"	2CK-T34	3CK-T34	1	86	Plug, 1/2-13 x 1/2"		3CK-T86	1
36	Trip plunger	2CK-T35	3CK-T35	1	87	Socket cap screw, 5/8 x 1-1/4"	2CK-T87	2CK-T87	* 5
37	Fil hd screw, 5/16-18 x 7/16"	2CK-T36	3CK-T36	2	88	Expansion plug, 2-1/4" diam	2CK-T88	3CK-T88	1
38	Trip plunger connecting block	2CK-T37	3CK-T37	1	89	Indicator lever carrier	2CK-T89	3CK-T89	1
39	Handwheel shaft and bevel pinton	2CK-T38	3CK-T38	1	90	Spring	2CK-T90	3CK-T90	1
40	New Departure brg, 20206	2CK-T39	3CK-T39	1	91	Pin	2CK-T91	3CK-T91	1
41	Dog pt set screw	2CK-T40	3CK-T40	1	92	Indicator lever	2CK-T92	3CK-T92	1
42	Hd feed reverse bevel gear bushing	2CK-T41	3CK-T41	2	93	Precision stop plunger	2CK-T93	3CK-T93	1
43	Hd feed reverse clutch miter gear	2CK-T42	3CK-T42	2	94	Spring	2CK-T94	3CK-T94	1
44	Thrust washer	2CK-T43	3CK-T43	1	95	Stop screw	2CK-T95	3CK-T95	1
45	Clutch shaft bevel brg retainer	2CK-T44	3CK-T44	1	96	Vert hd handwheel release yoke	2CK-T96	3CK-T96	1
46	Reverse clutch shaft bevel gear	2CK-T45	3CK-T45	1	97	Release yoke pin	2CK-T97	3CK-T97	1
47	Expansion plug, 1-3/8"	2CK-T46	3CK-T46	1	98	Release yoke carrier plate	2CK-T98	3CK-T98	1
48	Fil hd screw, 3/8-16 x 7/8"	2CK-T47	3CK-T47	4	99	Precision stop trip plunger	2CK-T99	3CK-T99	1
49	Reverse clutch shaft end brg	2CK-T48	3CK-T48	1	100	Acme Blue Label dowel, 1/2 x 1-1/2"	2CK-T100	3CK-T100	2
50	Hd feed reverse clutch	2CK-T49	3CK-T49	1	101	Power feed bracket cover plate	2CK-T101	3CK-T101	1
51	Hd feed reverse clutch shaft	2CK-T50	3CK-T50	1	102	Flat hd screw, 10-32 x 3/8"	2CK-T102	3CK-T102	2
51	Serrated dial collar	2CK-T51	3CK-T51	1					

* Six used on No. 3 machines

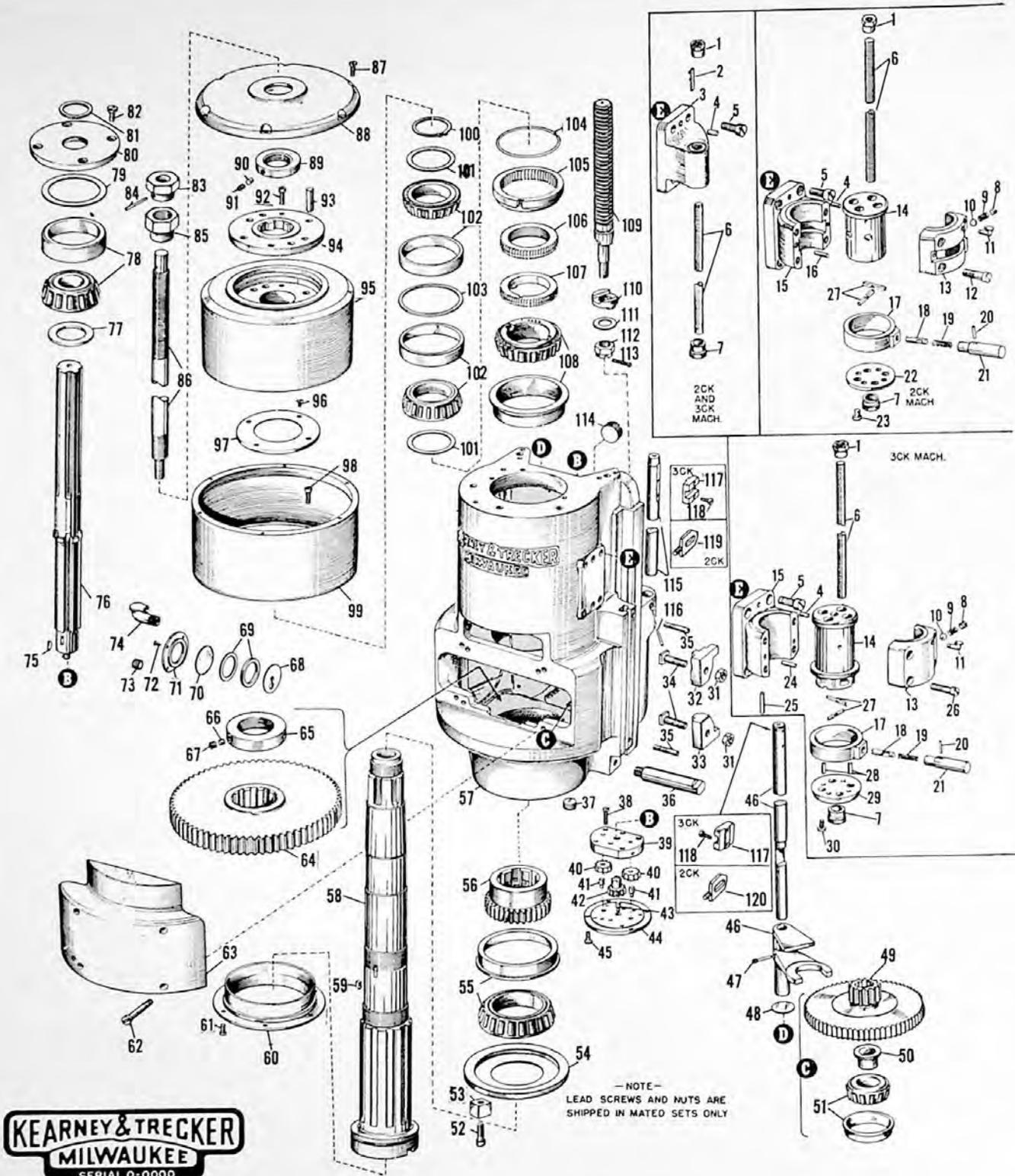

FIG. 23 - VERTICAL HEAD

Replacement Parts Manual

Milling Machines—Plain, Universal and Vertical

Fig. 23 - Vertical Head

Item No.	Part Name and Description	Code Nos.		Qty.
		2CK	3CK	
1	Nut	2CK-U1	3CK-U1	*4
2	Key	2CK-U2	3CK-U2	1
3	Single precision stop bracket	2CK-U3	3CK-U3	1
4	Acme Blue Label dowel. 1/2 x 1-1/4"			
		2CK-U4	3CK-U4	2
5	Fil hd screw. 1/2-13 x 1-1/8"	2CK-U5	3CK-U5	*4
6	Precision stop screw	2CK-U6	3CK-U6	*4
7	Precision stop graduated collar	2CK-U7	3CK-U7	1
8	Set screw. 7/16-14 x 1/2"	2CK-U8	3CK-U8	1
9	Spring	2CK-U9	3CK-U9	1
10	Steel ball. 3/8" diam	2CK-U10	3CK-U10	1
11	Gits oiler. #1204	2CK-U11	3CK-U11	1
12	Fil hd screw. 3/8-16 x 1-3/8"	2CK-U12		4
13	Precision stop bracket cap	2CK-U13	3CK-U13	1
14	Precision stop barrel	2CK-U14	3CK-U14	1
15	Precision stop bracket	2CK-U15	3CK-U15	1
18	Acme Blue Label dowel. 1/4 x 1-1/4"	2CK-U16		2
17	Precision stop adj ring	2CK-U17	3CK-U17	1
18	Precision stop ratchet pin	2CK-U18	3CK-U18	1
19	Spring	2CK-U19	3CK-U19	1
20	Taper pin. #00 x 3/4"	2CK-U20	3CK-U20	1
21	Precision stop ratchet	2CK-U21	3CK-U21	1
22	Precision stop barrel flange	2CK-U22		1
23	Flat hd mach screw. 1/4 x 5/8"	2CK-U23		4
24	Acme Blue Label dowel. 5/16 x 1-3/4"		3CK-U24	2
25	Pin		3CK-U25	1
26	Fil hd screw. 7/16-14 x 1-1/2"		3CK-U26	4
27	Key	2CK-U27	3CK-U27	2
28	Acme Blue Label dowel. 1/4 x 3/4"		3CK-U28	2
29	Precision stop cover		3CK-U29	1
30	Fil hd screw. 5/16-18 x 11/16"		3CK-U30	2
31	Hex nut	2CK-U31	3CK-U31	2
32	Upper trip dog	2CK-U32	3CK-U32	1
33	Lower trip dog	2CK-U33	3CK-U33	1
34	T-Bolt	2CK-U34	3CK-U34	2
35	Vert hd trip screw	2CK-U35	3CK-U35	2
36	Clamp rod	2CK-U36	3CK-U36	1
37	Pipe plug. C.S. 3/4"	2CK-U37	3CK-U37	1
38	Fil hd screw. 5/16-18 x 7/8"	2CK-U38	3CK-U38	6
39	Oil pump body	2CK-U39	3CK-U39	1
40	Oil pump gear (Driven)	2CK-U40	3CK-U40	2
41	Oil pump stud	2CK-U41	3CK-U41	2
42	Oil pump gear (Driver)	2CK-U42	3CK-U42	1
43	Oil pump stud	2CK-U43	3CK-U43	1
44	Vert hd oil pump cover	2CK-U44	3CK-U44	1
45	Fil hd screw. 5/16-18 x 11/16"	2CK-U45	3CK-U45	4
46	Range change shifter	2CK-U46	3CK-U46	1
47	Dowel screw	2CK-U47	3CK-U47	1
48	Expansion plug. 1-5/8"	2CK-U48	3CK-U48	1
49	Sliding spindle drive gear	2CK-U49	3CK-U49	1
50	Countershaft lower brg sleeve	2CK-U50	3CK-U50	1
51	Timken brg. 453B-461	2CK-U51		1
51	Timken brg. 453B-460		3CK-U51	1
52	Fil hd screw. 7/16-14 x 1-5/16"	2CK-U52	3CK-U52	2
53	Spindle drive key	2CK-U53	3CK-U53	2
54	Spindle oil slinger	2CK-U54	3CK-U54	1
55	Timken brg. 742B-749 (Spindle quality)	2CK-U55		1
55	Timken brg. 77675B-77375 (Spindle quality)		3CK-U55	1
56	Small spindle gear	2CK-U56	3CK-U56	1
57	Vert hd	2CK-U57	3CK-U57	1
58	Spindle	2CK-U58	3CK-U58	1
59	Key	2CK-U59	3CK-U59	1
60	Spindle oil retainer	2CK-U60	3CK-U60	1
61	Fil hd screw. 5/16-18 x 3/4"	2CK-U61	3CK-U61	6

Item No.	Part Name and Description	Code Nos.		Qty.
		2CK	3CK	
62	Fil hd screw. 3/8-16 x 2-1/2"	2CK-U62		4
62	Fil hd screw. 7/16-14 x 2-7/16"		3CK-U62	4
63	Vertical hd cover	2CK-U63	3CK-U63	1
64	Large spindle gear	2CK-U64	3CK-U64	1
65	Collar nut	2CK-U65	3CK-U65	1
66	Collar nut shoe	2CK-U66	3CK-U66	2
67	Socket set screw. 5/8 x 5/8"	2CK-U67	3CK-U67	2
68	Sight oil flow gauge	2CK-U68	3CK-U68	1
69	Oil gauge washer	2CK-U69	3CK-U69	2
70	Oil gauge glass	2CK-U70	3CK-U70	1
71	Oil flow gauge plate	2CK-U71	3CK-U71	1
72	Oval hd screw. 10-32 x 15/32"	2CK-U72	3CK-U72	4
73	Slotted pipe plug. 1/4"	2CK-U73	3CK-U73	1
74	Gits oiler. LP1401	2CK-U74	3CK-U74	1
75	Hi-pro key. HP-606	2CK-U75	3CK-U75	1
76	Spindle countershaft	2CK-U76	3CK-U76	1
77	Countershaft brg retaining washer	2CK-U77	3CK-U77	1
78	Timken brg. 522-527	2CK-U78		1
78	Timken brg. 612-615		3CK-U78	1
79	Countershaft brg adj washer	2CK-U79	3CK-U79	1
80	Spindle countershaft cover	2CK-U80	3CK-U80	1
81	Countershaft cover felt washer	2CK-U81	3CK-U81	1
82	Fil hd screw. 3/8-16 x 13/16"	2CK-U82		4
82	Hex hd screw. 3/8-16 x 1"		3CK-U82	6
83	Draw bolt hd	2CK-U83	3CK-U83	1
84	Taper pin. #4 x 1-1/4"	2CK-U84	3CK-U84	1
85	Draw bolt nut	2CK-U85	3CK-U85	1
86	Arbor draw-in bolt	2CK-U86	3CK-U86	1
87	Fil hd screw. 5/16-18 x 7/8"	2CK-U87	3CK-U87	6
88	Flywheel housing cover	2CK-U88	3CK-U88	1
89	Collar nut	2CK-U89	3CK-U89	1
90	Collar nut shoe	2CK-U90	3CK-U90	2
91	Socket set screw. 3/8 x 3/8"	2CK-U91	3CK-U91	2
92	Socket hd cap screw. 7/16 x 1-1/4"	2CK-U92	3CK-U92	3
93	Acme Blue Label dowel. 5/8 x 2-1/4"		3CK-U93	3
		2CK-U93		
94	Flywheel drive ring	2CK-U94	3CK-U94	1
95	Flywheel	2CK-U95	3CK-U95	1
96	Flat hd screw. 1/4 x 5/8"	2CK-U96	3CK-U96	4
97	Cover plate	2CK-U97	3CK-U97	1
98	Socket cap screw. 1/2 x 1-1/4"	2CK-U98	3CK-U98	5
99	Flywheel housing	2CK-U99	3CK-U99	1
100	Snap ring	2CK-U100	3CK-U100	*2
101	Spindle brg fitting washer	2CK-U101	3CK-U101	2
102	Timken brg. 33462-33275 (Spindle quality)			
		2CK-U102	3CK-U102	2
103	Spindle brg spacer	2CK-U103	3CK-U103	1
104	Snap ring	2CK-U104	3CK-U104	1
105	Spindle nut sleeve	2CK-U105	3CK-U105	1
106	Spindle brg drive collar nut	2CK-U106	3CK-U106	1
107	Spindle brg drive collar	2CK-U107	3CK-U107	1
108	Timken brg. 563B-567W (Spindle quality)			
		2CK-U108		1
108	Timken brg. 742B-750W (Spindle quality)		3CK-U108	1
109	Hd feed screw	2CK-U109	3CK-U109	1
110	Hd feed screw drive washer	2CK-U110	3CK-U110	1
111	Washer	2CK-U111	3CK-U111	1
112	Castellated nut. 7/8-14	2CK-U112	3CK-U112	1
113	Cotter pin. 1/8 x 1-3/4"	2CK-U113	3CK-U113	1
114	Plug	2CK-U114	3CK-U114	1
115	Gear shifter compensating rod	2CK-U115	3CK-U115	1
116	Taper pin. #5 x 2-3/8"	2CK-U116		1
116	Taper pin. #5 x 2-1/2"		3CK-U116	1
117	Shifter rod yoke		3CK-U117	2
118	Fil hd screw. 5/16-18 x 1"		3CK-U118	4
119	Compensating rod connecting link	2CK-U119		1
120	Shifter connecting link	2CK-U120		1

*Only one used on single position stop.

**Only one used on No. 3 machines

Replacement Parts Manual

10hp No. 2 and 15 hp No. 3 Model CK

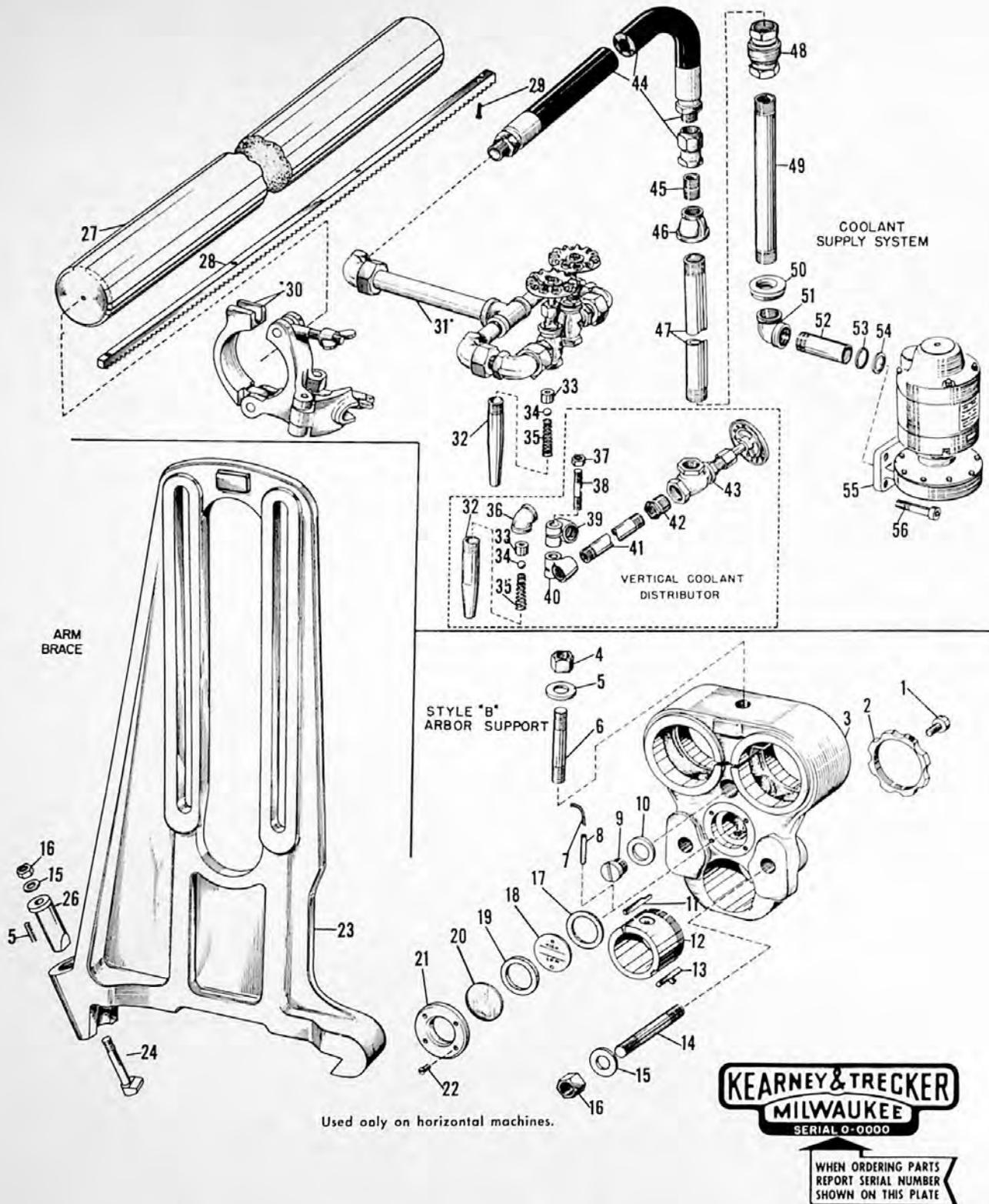

FIG. 24 - COOLANT SUPPLY SYSTEM, STYLE B ARBOR SUPPORT AND ARM BRACE

BUILDERS OF PRECISION AND PRODUCTION

KEARNEY & TRECKER
MILWAUKEE

MACHINE TOOLS FOR MILLING AND BORING

Replacement Parts Manual

Milling Machines—Plain, Universal and Vertical

Fig. 24 - Coolant Supply System, Style B Arbor Support And Arm Brace

Item No.	Part Name and Description	Code Nos.		Qty.	Item No.	Part Name and Description	Code Nos.		Qty.
		2CK	3CK				2CK	3CK	
STYLE B ARBOR SUPPORT AND ARM BRACE					COOLANT SUPPLY SYSTEM				
1	Fil hd screw. 3/8-16 x 11/16"	2CK-V1	3CK-V1	1	* 30	Coolant distributor support assy	2CK-V30	3CK-V30	1
2	Bushing nut	2CK-V2	3CK-V2	1	* 31	Coolant distributor complete	2CK-V31	3CK-V31	1
3	Style B arbor support	2CK-V3	3CK-V3	1	32	Coolant nozzle	2CK-V32	3CK-V32	† 2
4	Hex nut. 3/4-10"	2CK-V4	3CK-V4	1	33	Nozzle ball retainer	2CK-V33	3CK-V33	† 2
5	Washer. 3/4"	2CK-V5	3CK-V5	1	34	Steel ball. 1/2" diam	2CK-V34	3CK-V34	† 2
6	Stud	2CK-V6	3CK-V6	1	35	Spring	2CK-V35	3CK-V35	† 2
7	Oil wicking	2CK-V7	3CK-V7	1	36	Elbow. 1/2" x 90°	2CK-V36	3CK-V36	1
8	Copper tube. 1/4 x 2-7/8"	2CK-V8	3CK-V8	1	37	Hex nut. 7/16-14"	2CK-V37	3CK-V37	1
9	Oil filler plug	2CK-V9	3CK-V9	1	38	Stud	2CK-V38	3CK-V38	1
10	Fibre washer	2CK-V10	3CK-V10	1	39	Coolant pipe clamp	2CK-V39	3CK-V39	1
11	Oil retainer	2CK-V11	3CK-V11	1	40	Coolant pipe clamp	2CK-V40	3CK-V40	1
12	Arbor support bushing	2CK-V12	3CK-V12	1	41	Coolant pipe	2CK-V41	3CK-V41	1
13	Key	2CK-V13	3CK-V13	1	42	Hex reducer bushing. 3/4 x 1/2"	2CK-V42	3CK-V42	1
14	Stud	2CK-V14	3CK-V14	2	43	Angle valve. 3/4" x 90°	2CK-V43	3CK-V43	1
15	Washer. 5/8"	2CK-V15	3CK-V15	3	44	Flexible coolant hose	2CK-V44	3CK-V44	1
16	Hex nut. 5/8-11"	2CK-V16	3CK-V16	3	45	Nipple. 3/4 x 3"	2CK-V45	3CK-V45	1
17	Oil guage washer	2CK-V17	3CK-V17	1	46	Reducer. 1 x 3/4"	2CK-V46	3CK-V46	1
18	Oil guage back plate	2CK-V18	3CK-V18	1	47	Wrought iron pipe. 1 x 23"	2CK-V47		1
19	Oil guage washer	2CK-V19	3CK-V19	1	47	Wrought iron pipe. 1 x 24-3/4"		3CK-V47	1
20	Oil guage glass	2CK-V20	3CK-V20	1	48	Vert screwed brass check valve. No. 24 x 1"	2CK-V48	3CK-V48	1
21	Oil guage plate	2CK-V21	3CK-V21	1	49	Wrought iron pipe. 1 x 8"	2CK-V49	3CK-V49	1
22	Oval hd screw. 10-32 x 15/32"	2CK-V22	3CK-V22	4	50	Coolant pipe seal	2CK-V50	3CK-V50	1
23	Arm brace	2CK-V23	3CK-V23	1	51	Elbow. unbanded. 1" x 90	2CK-V51	3CK-V51	1
24	Clamp stud	2CK-V24	3CK-V24	1	52	Coolant pipe	2CK-V52	3CK-V52	1
25	Spring	2CK-V25	3CK-V25	1	53	"O" Ring. #24 (1/8 x 1-5/16 x 1-9/16")	2CK-V53	3CK-V53	1
26	Clamp sleeve	2CK-V26	3CK-V26	1	54	Sealing washer	2CK-V54	3CK-V54	1
OVERARMS					55	Special Gusher pump	2CK-V55	3CK-V55	1
27	Overarm (Horiz. mach only)	2CK-V27	3CK-V27	2	56	Sock cap screw. 1/2 x 7/8"	2CK-V56	3CK-V56	4
28	Overarm rack	2CK-V28	3CK-V28	2					
29	Fil hd screw. 5/16-18 x 11/16"	2CK-V29		8					
29	Fil hd screw. 5/16-24 x 11/16"		3CK-V29	10					

* Used only on horizontal machines.

† Only one used on vertical machines

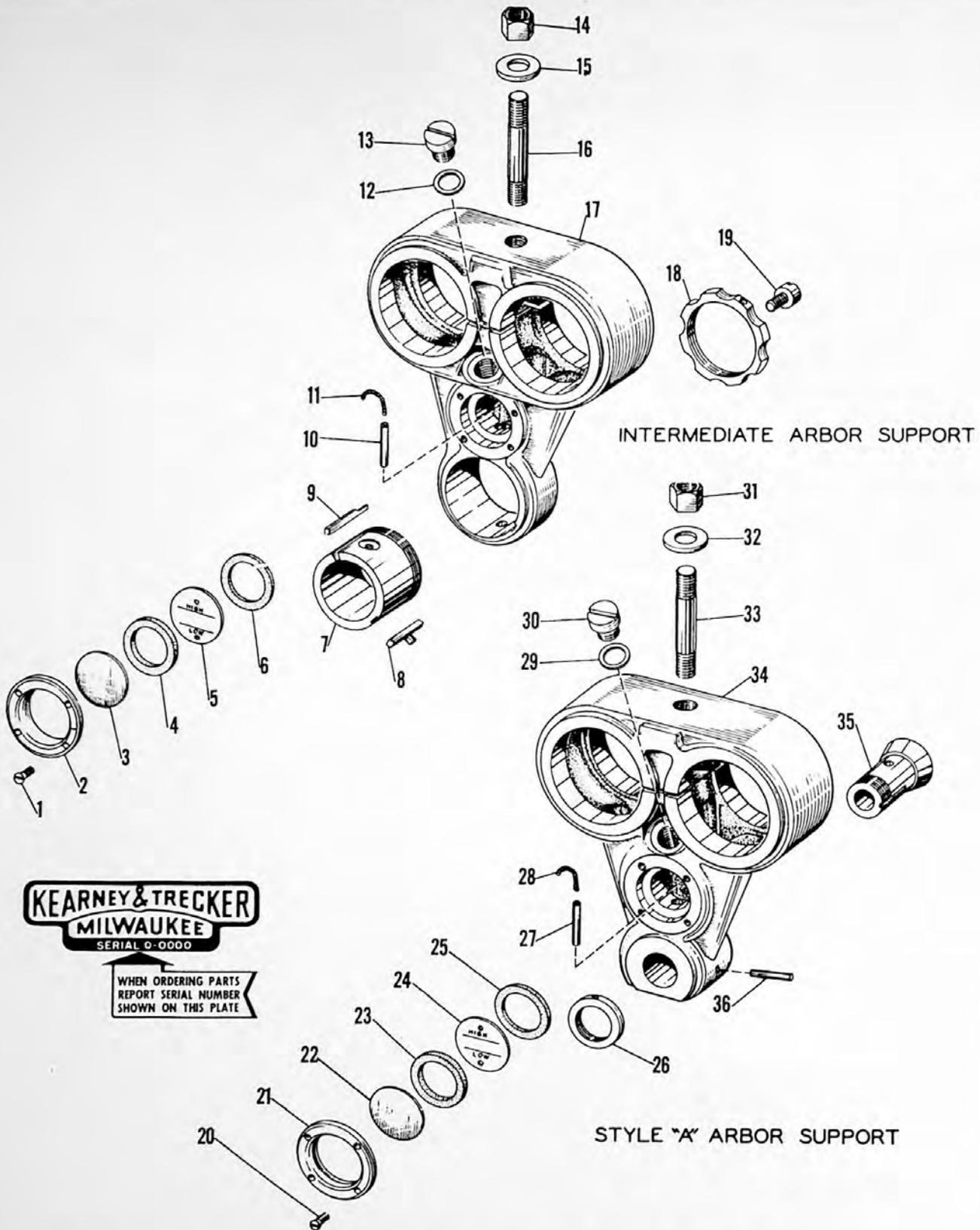

FIG. 25 - INTERMEDIATE ARBOR SUPPORT AND STYLE A ARBOR SUPPORT

FIG. 25 - INTERMEDIATE STYLE ARBOR SUPPORT AND STYLE A ARBOR SUPPORT

Item No.	Part Name and Description	Code Nos.		Qty.
		2CK	3CK	
INTERMEDIATE ARBOR SUPPORT				
1	Oval hd screw, 10-32 x 15/32"	2CK-W1	3CK-W1	4
2	Oil guage plate	2CK-W2	3CK-W2	1
3	Oil guage glass	2CK-W3	3CK-W3	1
4	Oil guage washer	2CK-W4	3CK-W4	1
5	Oil guage back plate	2CK-W5	3CK-W5	1
6	Oil guage washer	2CK-W6	3CK-W6	1
7	Arbor support bushing	2CK-W7	3CK-W7	1
8	Key	2CK-W8	3CK-W8	1
9	Oil retainer	2CK-W9	3CK-W9	1
10	Copper tube, 1/4 x 2-5/16"	2CK-W10		1
10	Copper tube, 1/4 x 2-1/4"		3CK-W10	1
11	Oil wicking	2CK-W11	3CK-W11	1
12	Fibre washer	2CK-W12	3CK-W12	1
13	Oil filler plug	2CK-W13	3CK-W13	1
14	Hex nut, 3/4-10"	2CK-W14	3CK-W14	1
15	Washer, 3/4"	2CK-W15	3CK-W15	1
16	Stud	2CK-W16	3CK-W16	1
17	Intermediate arbor support	2CK-W17	3CK-W17	1
18	Bushing nut	2CK-W18	3CK-W18	1
19	Fil hd screw, 3/8-16 x 11/16"	2CK-W19	3CK-W19	1
STYLE A ARBOR SUPPORT				
20	Oval hd screw, 10-32 x 15/32"	2CK-W20	3CK-W20	4
21	Oil guage plate	2CK-W21	3CK-W21	1
22	Oil guage glass	2CK-W22	3CK-W22	1
23	Oil guage washer	2CK-W23	3CK-W23	1
24	Oil guage back plate	2CK-W24	3CK-W24	1
25	Oil guage washer	2CK-W25	3CK-W25	1
26	Bushing nut	2CK-W26	3CK-W26	1
27	Copper tube, 1/4 x 3"	2CK-W27		1
27	Copper tube, 1/4 x 3-7/8"		3CK-W27	1
28	Oil wicking	2CK-W28	3CK-W28	1
29	Fibre washer	2CK-W29	3CK-W29	1
30	Oil filler plug	2CK-W30	3CK-W30	1
31	Hex nut, 3/4-10"	2CK-W31	3CK-W31	1
32	Washer, 3/4"	2CK-W32	3CK-W32	1
33	Stud	2CK-W33	3CK-W33	1
34	Style A arbor support	2CK-W34	3CK-W34	1
35	Bushing	2CK-W35	3CK-W35	1
36	Pin	2CK-W36	3CK-W36	1



WHEN ORDERING PARTS
REPORT SERIAL NUMBER
SHOWN ON THIS PLATE

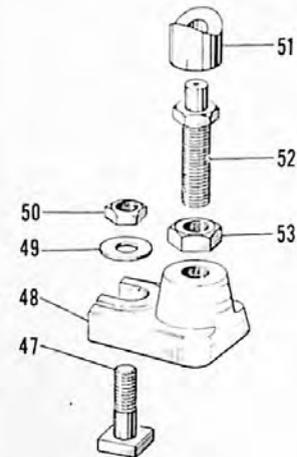
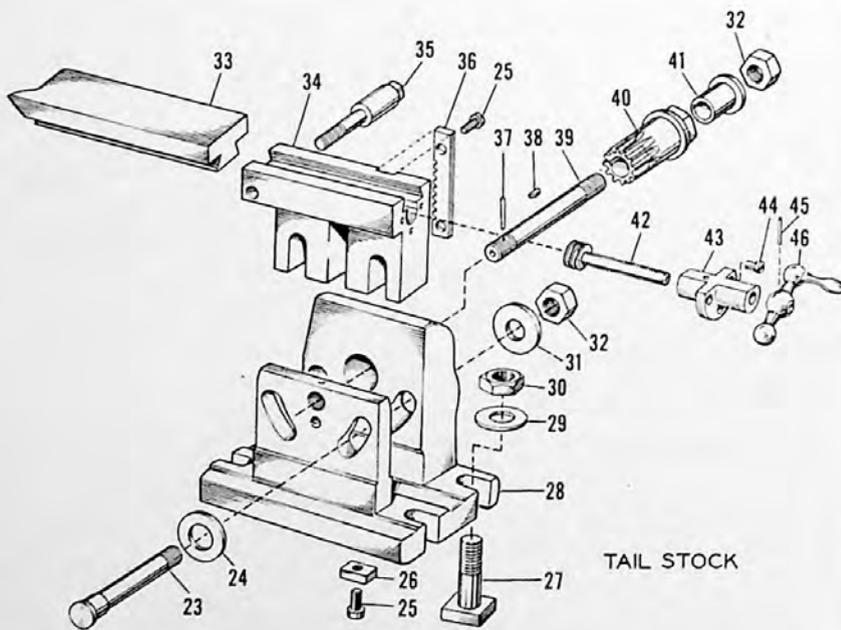
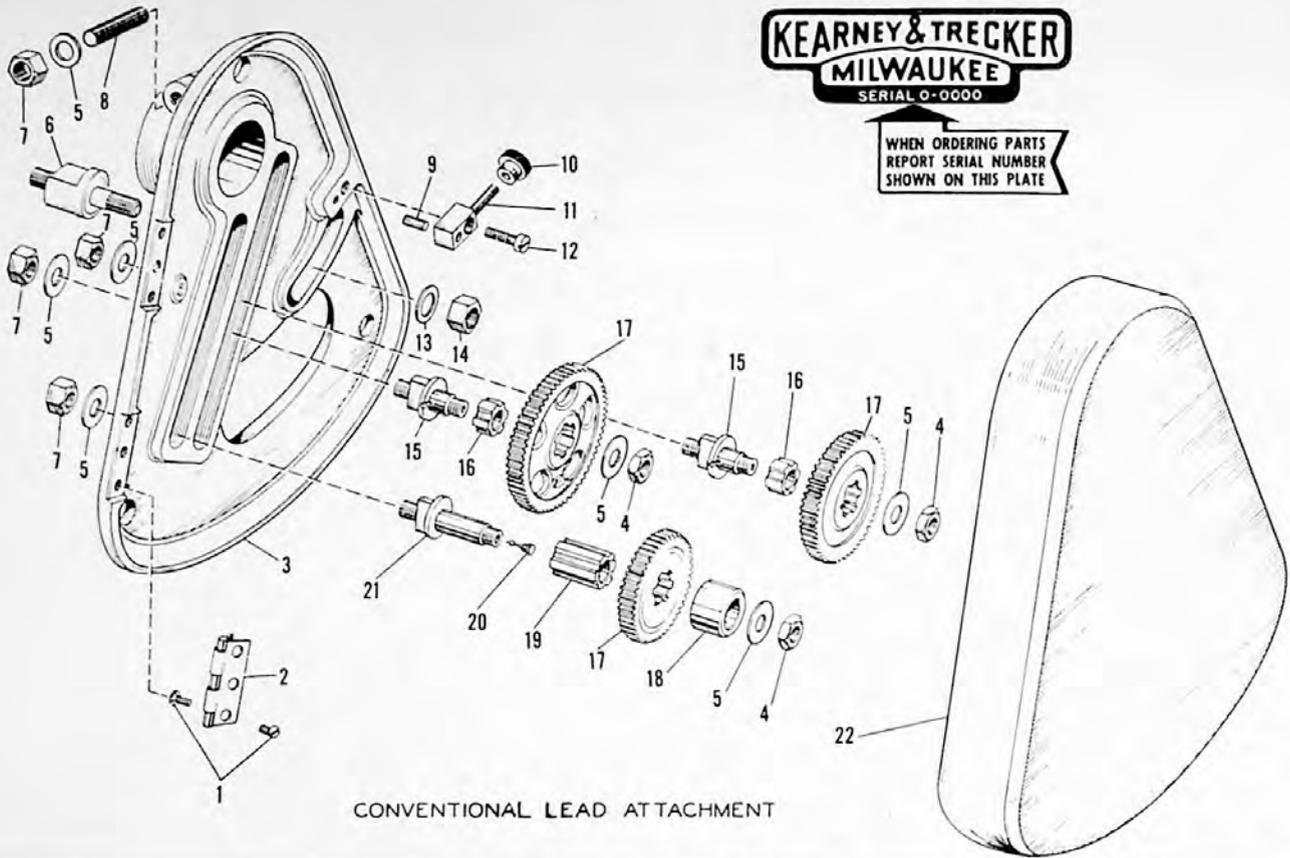

FIG. 26 - CONVENTIONAL LEAD ATTACHMENT, TAIL STOCK & STEADY REST

Replacement Parts Manual

Milling Machines—Plain, Universal and Vertical

Fig. 26 - Conventional Lead Attachment, Tail Stock and Steady Rest

Item No.	Part Name and Description	Code Nos.		Qty.
		2CK	3CK	
1	Flat head screw, 10-32 x 1/2"	2CK-X1	3CK-X1	12
2	Butt hinge, #800 Stanley	2CK-X2	3CK-X2	2
3	Change gear bracket *	2CK-X3	3CK-X3	1
4	Hex nut, 1/2-13	2CK-X4	3CK-X4	3
5	Washer, 1/2"	2CK-X5	3CK-X5	7
6	Change gear bracket stud	2CK-X6	3CK-X6	1
7	Hex nut, 1/2-13	2CK-X7	3CK-X7	4
8	Stud	2CK-X8	3CK-X8	1
9	Acme blue label dowel, 1/4 x 7/8"	2CK-X9	3CK-X9	1
10	Knurled nut	2CK-X10	3CK-X10	1
11	Door lock bolt	2CK-X11	3CK-X11	1
12	Fillister head screw, 5/16-18 x 1"	2CK-X12	3CK-X12	1
13	Washer	2CK-X13	3CK-X13	1
14	Hex nut	2CK-X14	3CK-X14	1
15	Idler stud	2CK-X15	3CK-X15	2
16	Splined bushing, short	2CK-X16	3CK-X16	2
17	Change gears			
	Change gear 24T - 12P	2CK-X17	3CK-X17	1
	Change gear 28T - 12P	2CK-X18	3CK-X18	1
	Change gear 32T - 12P	2CK-X19	3CK-X19	1
	Change gear 40T - 12P	2CK-X20	3CK-X20	1
	Change gear 44T - 12P	2CK-X21	3CK-X21	1
	Change gear 48T - 12P	2CK-X22	3CK-X22	2
	Change gear 56T - 12P	2CK-X23	3CK-X23	1
	Change gear 64T - 12P	2CK-X24	3CK-X24	1
	Change gear 72T - 12P	2CK-X25	3CK-X25	1
	Change gear 86T - 12P	2CK-X26	3CK-X26	1
	Change gear 100T - 12P	2CK-X27	3CK-X27	1
18	Spacing collars			
	Spacing collar, small	2CK-X28	3CK-X28	1
	Spacing collar, large	2CK-X29	3CK-X29	1
19	Splined bushing, long	2CK-X30	3CK-X30	1
20	Gits oiler, RS-531	2CK-X31	3CK-X31	1
21	Differential index compound stud	2CK-X32	3CK-X32	1
22	Change gear bracket cover	2CK-X33	3CK-X33	1

Item No.	Part Name and Description	Code Nos.		Qty.
		2CK	3CK	
TAIL STOCK				
23	Clamp screw	2CK-X34	3CK-X34	2
24	Washer, 5/8"	2CK-X35	3CK-X35	2
25	Fillister head screw, 5/16-18 x 1 1/16"	2CK-X36	3CK-X36	4
26	Tongue	2CK-X37	3CK-X37	2
27	T-Bolt	2CK-X38	3CK-X38	4
28	Tail stock	2CK-X39	3CK-X39	1
29	Washer, 5/8"	2CK-X40	3CK-X40	4
30	Hex nut, 5/8-11	2CK-X41	3CK-X41	4
31	Washer, 5/8"	2CK-X42	3CK-X42	2
32	Hex nut, 3/4"	2CK-X43	3CK-X43	3
33	Center	2CK-X44	3CK-X44	1
34	Center block	2CK-X45	3CK-X45	1
35	Center locking screw	2CK-X46	3CK-X46	1
36	Elevating rack	2CK-X47	3CK-X47	1
37	Taper pin, #1 x 1-1/8"	2CK-X48	3CK-X48	1
38	Hi-Pro key, HP-504	2CK-X49	3CK-X49	1
39	Clamping stud	2CK-X50	3CK-X50	1
40	Elevating rack pinion	2CK-X51	3CK-X51	1
41	Sleeve	2CK-X52	3CK-X52	1
42	Center adjusting worm	2CK-X53	3CK-X53	1
43	Worm sleeve	2CK-X54	3CK-X54	1
44	Fillister head screw, 1/4-20 x 1/2"	2CK-X55	3CK-X55	3
45	Taper pin, #1 x 13/16"	2CK-X56	3CK-X56	1
46	Ball crank, No. 00	2CK-X57	3CK-X57	1
STEADY REST				
47	T-Bolt	2CK-X58	3CK-X58	1
48	Steady rest base	2CK-X59	3CK-X59	1
49	Washer, 5/8"	2CK-X60	3CK-X60	1
50	Hex nut, 5/8"	2CK-X61	3CK-X61	1
51	Steady rest vee block	2CK-X62	3CK-X62	1
52	Steady rest adjusting screw	2CK-X63	3CK-X63	1
53	Hex nut, 3/4-10	2CK-X64	3CK-X64	1



WHEN ORDERING PARTS
REPORT SERIAL NUMBER
SHOWN ON THIS PLATE

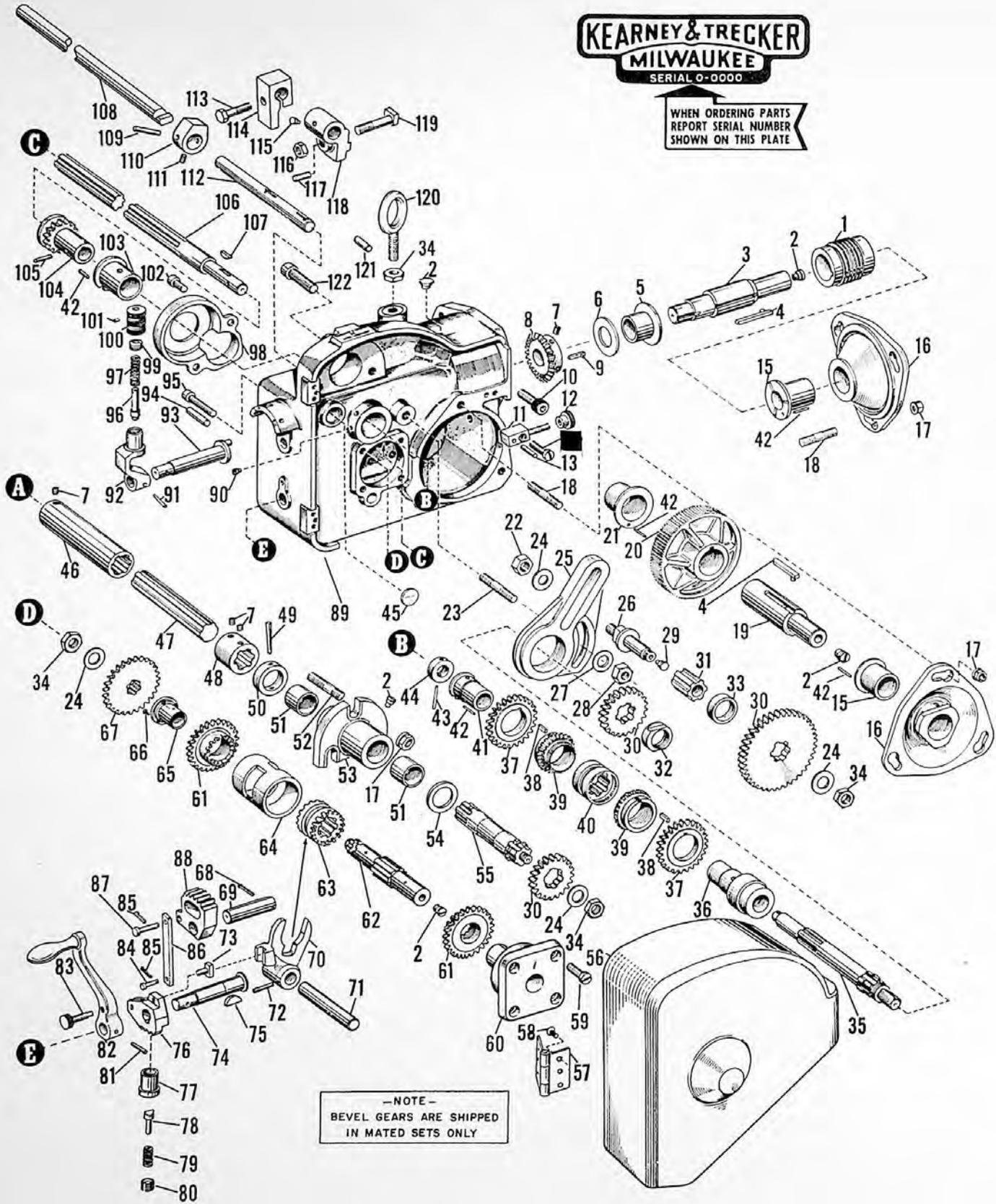

FIG. 27 - LOW LEAD ATTACHMENT

BUILDERS OF PRECISION AND PRODUCTION



MACHINE TOOLS FOR MILLING AND BORING

Fig. 27 - Low Lead Attachment

Item No.	Part Name and Description	Code Nos.		Qty.
		2CK	3CK	
1	Worms			
	Worm 24-1	2CK-Y1	3CK-Y1	1
	Worm 96-1	2CK-Y2	3CK-Y2	1
	Worm 24-8	2CK-Y3	3CK-Y3	1
2	Gits oiler, RS-533	2CK-Y4	3CK-Y4	9
3	Worm and worm wheel shaft	2CK-Y5	3CK-Y5	1
4	Key	2CK-Y6	3CK-Y6	2
5	Worm and worm wheel shaft bushing	2CK-Y7	3CK-Y7	1
6	Reverse bevel gear washer	2CK-Y8	3CK-Y8	1
7	Socket dog point screw, 5/16 x 5/16"	2CK-Y9	3CK-Y9	4
8	Reverse bevel gear	2CK-Y10	3CK-Y10	1
9	Key	2CK-Y11	3CK-Y11	1
10	Socket cap screw, 1/2-13 x 1-1/2"	2CK-Y12		2
	Socket cap screw, 5/8-13 x 1-1/2"		3CK-Y12	2
11	Door lock bolt	2CK-Y13	3CK-Y13	1
12	Knurled nut	2CK-Y14	3CK-Y14	1
13	Acme blue label dowel, 1/4 x 7/8"	2CK-Y15	3CK-Y15	1
14	Fillister head screw, 5/16-18 x 1"	2CK-Y16	3CK-Y16	1
15	Worm and worm wheel support bearing bushing	2CK-Y17	3CK-Y17	2
16	Worm and worm wheel support bearing	2CK-Y18	3CK-Y18	2
17	Hex collar nut	2CK-Y19	3CK-Y19	9
18	Stud	2CK-Y20	3CK-Y20	6
19	Table screw extension	2CK-Y21	3CK-Y21	1
20	Worm wheels			
	Worm wheel 24-1	2CK-Y22	3CK-Y22	1
	Worm wheel 96-1	2CK-Y23	3CK-Y23	1
	Worm wheel 24-8	2CK-Y24	3CK-Y24	1
21	Table screw extension bushing	2CK-Y25	3CK-Y25	1
22	Hex nut, 1/2-13	2CK-Y26	3CK-Y26	1
23	Stud	2CK-Y27	3CK-Y27	1
24	Washer, 1/2"	2CK-Y28	3CK-Y28	4
25	Change gear arm	2CK-Y29	3CK-Y29	1
26	Change gear stud	2CK-Y30	3CK-Y30	1
27	Washer, 1/2"	2CK-Y31	3CK-Y31	1
28	Hex nut	2CK-Y32	3CK-Y32	1
29	Gits oiler, RS-531	2CK-Y33	3CK-Y33	1
30	Change gears			
	Change gear 20T 10P	2CK-Y34	3CK-Y34	2
	Change gear 21T 10P	2CK-Y35	3CK-Y35	1
	Change gear 22T 10P	2CK-Y36	3CK-Y36	1
	Change gear 23T 10P	2CK-Y37	3CK-Y37	1
	Change gear 24T 10P	2CK-Y38	3CK-Y38	1
	Change gear 25T 10P	2CK-Y39	3CK-Y39	1
	Change gear 26T 10P	2CK-Y40	3CK-Y40	1
	Change gear 27T 10P	2CK-Y41	3CK-Y41	1
	Change gear 28T 10P	2CK-Y42	3CK-Y42	1
	Change gear 29T 10P	2CK-Y43	3CK-Y43	1
	Change gear 30T 10P	2CK-Y44	3CK-Y44	1
	Change gear 32T 10P	2CK-Y45	3CK-Y45	1
	Change gear 34T 10P	2CK-Y46	3CK-Y46	1
	Change gear 36T 10P	2CK-Y47	3CK-Y47	1
	Change gear 38T 10P	2CK-Y48	3CK-Y48	1
	Change gear 40T 10P	2CK-Y49	3CK-Y49	1
31	Splined bushing	2CK-Y50	3CK-Y50	1

Item No.	Part Name and Description	Code Nos.		Qty.
		2CK	3CK	
32	Hand crank shaft nut	2CK-Y51	3CK-Y51	1
33	Spacing collar	2CK-Y52	3CK-Y52	1
34	Hex nut, 1/2-13	2CK-Y53	3CK-Y53	4
35	Hand crank shaft	2CK-Y54	3CK-Y54	1
36	Hand crank shaft support bearing	2CK-Y55	3CK-Y55	1
37	Hand crank shaft spur gear	2CK-Y56	3CK-Y56	2
38	Key	2CK-Y57	3CK-Y57	2
39	Reverse clutch bevel gear	2CK-Y58	3CK-Y58	2
40	Reverse clutch	2CK-Y59	3CK-Y59	1
41	Hand crank shaft bushing	2CK-Y60	3CK-Y60	1
42	Pin, 1/8 x 1/2"	2CK-Y61	3CK-Y61	5
43	Taper pin, #2 x 1-1/4"	2CK-Y62	3CK-Y62	1
44	Hand crank shaft collar	2CK-Y63	3CK-Y63	1
45	Expansion plug, 1" dia	2CK-Y64	3CK-Y64	1
46	Spiral head drive shaft connector (long)	2CK-Y65	3CK-Y65	1
47	Spiral head drive shaft extension	2CK-Y66	3CK-Y66	1
48	Spiral head drive shaft connector (short)	2CK-Y67	3CK-Y67	1
49	Taper pin, #4 x 1-5/8"	2CK-Y68	3CK-Y68	1
50	Spiral head drive shaft collar	2CK-Y69	3CK-Y69	1
51	Spiral head drive shaft support bracket bushing	2CK-Y70	3CK-Y70	2
52	Stud	2CK-Y71	3CK-Y71	3
53	Spiral head drive shaft support bracket	2CK-Y72	3CK-Y72	1
54	Spiral head drive shaft washer	2CK-Y73	3CK-Y73	3
55	Spiral head drive shaft	2CK-Y74	3CK-Y74	1
56	Spiral change gear box cover	2CK-Y75	3CK-Y75	1
57	Stanley butt hinge, No. 800	2CK-Y76	3CK-Y76	2
58	Flat head screw, 10-32 x 1/2"	2CK-Y77	3CK-Y77	12
59	Fillister head screw, 3/8-16 x 5/8"	2CK-Y78	3CK-Y78	4
60	Reverse gear shaft bearing (right hand)	2CK-Y79	3CK-Y79	1
61	Reverse gear	2CK-Y80	3CK-Y80	2
62	Reverse gear shaft	2CK-Y81	3CK-Y81	1
63	Reverse gear shaft clutch	2CK-Y82	3CK-Y82	1
64	Reverse gear spacer	2CK-Y83	3CK-Y83	1
65	Reverse gear shaft bearing (left hand)	2CK-Y84	3CK-Y84	1
66	Flat head screw, 3/16-32 x 1/2"	2CK-Y85	3CK-Y85	3
67	Reverse shaft driving gear	2CK-Y86	3CK-Y86	1
68	Cotter pin, 7/64 x 1"	2CK-Y87	3CK-Y87	1
69	Trip segment shaft	2CK-Y88	3CK-Y88	1
70	Clutch shifter	2CK-Y89	3CK-Y89	1
71	Clutch shifter shaft	2CK-Y90	3CK-Y90	1
72	Taper pin set screw	2CK-Y91	3CK-Y91	1
73	Detent block shifter shoe	2CK-Y92	3CK-Y92	1
74	Direction lever shaft	2CK-Y93	3CK-Y93	1
75	Hi-Pro key HP-706	2CK-Y94	3CK-Y94	1
76	Detent block	2CK-Y95	3CK-Y95	1
77	Detent plunger sleeve	2CK-Y96	3CK-Y96	1
78	Detent plunger	2CK-Y97	3CK-Y97	1
79	Detent spring	2CK-Y98	3CK-Y98	1
80	Detent plunger screw	2CK-Y99	3CK-Y99	1

Item No.	Part Name and Description	Code Nos.		Qty.
		2CK	3CK	
81	Taper pin, #3 x 1-1/8"	2CK-Y100	3CK-Y100	1
82	Direction lever and handle	2CK-Y101	3CK-Y101	1
83	Knurled head screw	2CK-Y102	3CK-Y102	1
84	Connecting link pin (short)	2CK-Y103	3CK-Y103	1
85	Cotter pin, 3/32 x 3/4"	2CK-Y104	3CK-Y104	1
86	Connecting link	2CK-Y105	3CK-Y105	1
87	Connecting link pin (long)	2CK-Y106	3CK-Y106	1
88	Trip segment	2CK-Y107	3CK-Y107	1
89	Spiral change gear box	2CK-Y108	3CK-Y108	1
90	Dog point set screw, 1/4-20 x 15/32"	2CK-Y109	3CK-Y109	1
91	Taper pin, #2 x 1-1/16"	2CK-Y110	3CK-Y110	1
92	Selection lever	2CK-Y111	3CK-Y111	1
93	Reverse eccentric shaft	2CK-Y112	3CK-Y112	1
94	Acme blue label dowel, 3/8 x 2-1/4"	2CK-Y113		1
	Acme blue label dowel, 1/2 x 2-1/2"		3CK-Y113	1
95	Socket cap screw, 1/2-13 x 2"	2CK-Y114		1
96	Selection lever plunger	2CK-Y115	3CK-Y115	1
97	Spring	2CK-Y116	3CK-Y116	1
98	Clutch shaft gear guard	2CK-Y117	3CK-Y117	1
99	Plunger guide	2CK-Y118	3CK-Y118	1
100	Selection lever knob	2CK-Y119	3CK-Y119	1
101	Cone point set screw, 8-32 x 3/8"	2CK-Y120	3CK-Y120	1
102	Socket cap screw, 1/2 x 1"	2CK-Y121	3CK-Y121	2
103	Auxiliary drive shaft bushing	2CK-Y122	3CK-Y122	1
104	Auxiliary drive shaft bushing pinion	2CK-Y123	3CK-Y123	1
105	Taper pin, #4 x 1-1/16"	2CK-Y124	3CK-Y124	1
106	Auxiliary drive shaft	2CK-Y125	3CK-Y125	1
107	Hi-Pro key, HP-906	2CK-Y126	3CK-Y126	1
108	Trip shaft	2CK-Y127	3CK-Y127	1
109	Taper pin, #4 x 1-3/8"	*3CK-Y128		1
110	Trip shaft key	3CK-Y129		1
111	Socket set screw, 1/4-20 x 1/4"	*3CK-Y130		1
112	Trip rack	2CK-Y131	3CK-Y131	1
113	Hex head screw, 3/8-16 x 1-1/4"	2CK-Y132	3CK-Y132	2
114	Trip dog	2CK-Y133	3CK-Y133	2
115	Gits oiler, RS-531	2CK-Y134	3CK-Y134	1
116	Hex nut, 7/16-14	2CK-Y135	3CK-Y135	2
117	Acme blue label dowel, 1/4 x 1-1/2"	2CK-Y136	3CK-Y136	2
118	Trip shaft support bracket	2CK-Y137	3CK-Y137	2
119	T-Bolt	2CK-Y138	3CK-Y138	1
120	Eye bolt, 1/2"	2CK-Y139	3CK-Y139	1
121	Acme blue label dowel, 3/8 x 1-3/8"	2CK-Y140		1
	Acme blue label dowel, 1/2 x 1-1/2"		3CK-Y140	1
122	Socket cap screw, 1/2 x 2-1/2"	2CK-Y141		1
	Socket cap screw, 1/2 x 2-1/4"		3CK-Y141	1

* No. 3 machines only

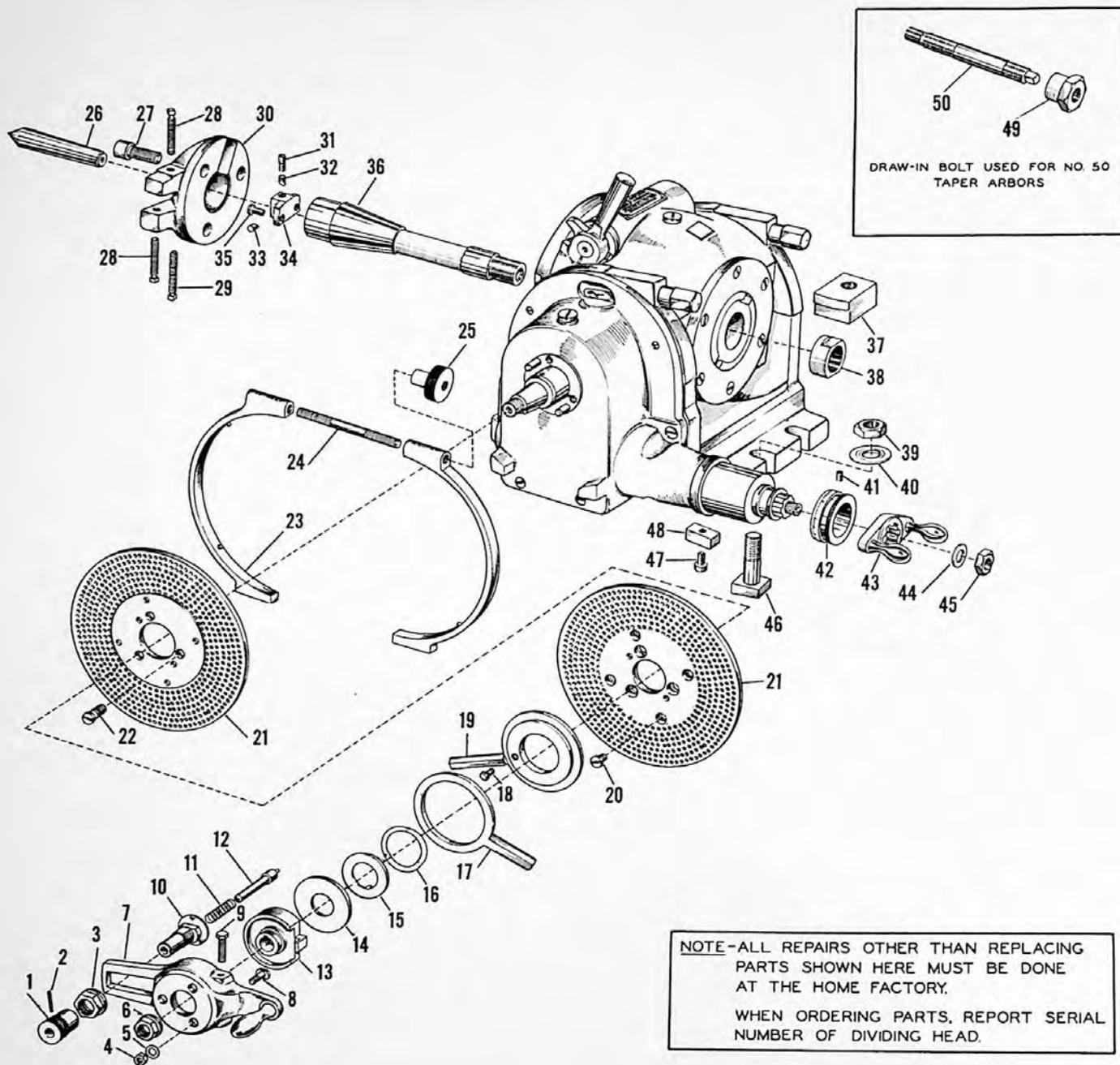

KEARNEY & TRECKER
MILWAUKEE
SERIAL 0-0000

WHEN ORDERING PARTS
REPORT SERIAL NUMBER
SHOWN ON THIS PLATE

FIG. 28 - MODEL K DIVIDING HEAD

Replacement Parts Manual

Milling Machines—Plain, Universal and Vertical

Fig. 28 - Model K Dividing Head

Item No.	Part Name and Description	Code Nos.		Qty.
		2CK	3CK	
1	Index plunger knob	2CK-Z1	3CK-Z1	1
2	Taper pin, #1 x 1-1/16"	2CK-Z2	3CK-Z2	1
3	Clamp nut	2CK-Z3	3CK-Z3	1
4	Hex nut, 3/8-16	2CK-Z4	3CK-Z4	3
5	Washer, 3/8"	2CK-Z5	3CK-Z5	3
6	Clamp nut	2CK-Z6	3CK-Z6	1
7	Index crank	2CK-Z7	3CK-Z7	1
8	Tee bolt, 3/8-16 x 13/16"	2CK-Z8	3CK-Z8	3
9	Adjusting screw, 3/8-24 x 1-1/8"	2CK-Z9	3CK-Z9	2
10	Index plunger sleeve	2CK-Z10	3CK-Z10	1
11	Spring	2CK-Z11	3CK-Z11	1
12	Index plunger	2CK-Z12	3CK-Z12	1
13	Index crank adjusting lever	2CK-Z13	3CK-Z13	1
14	Index crank back plate	2CK-Z14	3CK-Z14	1
15	Spring retainer	2CK-Z15	3CK-Z15	1
16	Spring	2CK-Z16	3CK-Z16	1
17	Index finger	2CK-Z17	3CK-Z17	1
18	Hex head screw, 10-32 x 1/16"	2CK-Z18	3CK-Z18	1
19	Index finger	2CK-Z19	3CK-Z19	1
20	Fillister head screw, 5/16-18 x 7/16"	2CK-Z20	3CK-Z20	4
21	Index plates			
	Index plate, 100-96-92-84- 72-66-60	2CK-Z21	3CK-Z21	1
	Index plate, 98-88-78-76- 68-58-54	2CK-Z22	3CK-Z22	1
	Index plate, 99-91-83-77- 69-62-56	2CK-Z23	3CK-Z23	1
	Index plate, 94-87-81-73- 64-59-52	2CK-Z24	3CK-Z24	1
	Index plate, 97-89-82-74- 67-61-53	2CK-Z25	3CK-Z25	1
	Index plate, 93-86-79-71- 63-57-51	2CK-Z26	3CK-Z26	1

Item No.	Part Name and Description	Code Nos.		Qty.
		2CK	3CK	
22	Fillister head screw, 3/8-16 x 1-3/32"	2CK-Z27	3CK-Z27	3
23	Index plate clamp ring	2CK-Z28	3CK-Z28	1
24	Stud	2CK-Z29	3CK-Z29	1
25	Knurled nut	2CK-Z30	3CK-Z30	1
26	Center	2CK-Z31	3CK-Z31	1
27	Allen head screw, 5/8 x 1-1/2"	2CK-Z32	3CK-Z32	3
28	Square head set screw, 3/8-16 x 3/4"	2CK-Z33	3CK-Z33	2
29	Square head set screw, 3/8-16 x 1"	2CK-Z34	3CK-Z34	1
30	Driving dog	2CK-Z35	3CK-Z35	1
31	Spindle drive key screw	2CK-Z36	3CK-Z36	1
32	Expansion key plug	2CK-Z37	3CK-Z37	1
33	Expansion wedge key	2CK-Z38	3CK-Z38	1
34	Spindle drive expansion key	2CK-Z39	3CK-Z39	1
35	Fillister head screw, 1/4-20 x 11/16"	2CK-Z40	3CK-Z40	2
36	Centering plug	2CK-Z41	3CK-Z41	1
37	Clamp block	2CK-Z42	3CK-Z42	1
38	Nut	2CK-Z43	3CK-Z43	1
39	Hex nut, 5/8-11	2CK-Z44	3CK-Z44	5
40	Washer, 5/8"	2CK-Z45	3CK-Z45	5
41	Allen set screw, 5/16-18 x 3/8"	2CK-Z46	3CK-Z46	1
42	Graduated collar	2CK-Z47	3CK-Z47	1
43	Crank	2CK-Z48	3CK-Z48	1
44	Washer, 1/2"	2CK-Z49	3CK-Z49	1
45	Hex nut, 1/2-13	2CK-Z50	3CK-Z50	1
46	Tee bolt	2CK-Z51	3CK-Z51	5
47	Fillister head screw, 5/16-18 x 11/16"	2CK-Z52	3CK-Z52	2
48	Vise tongue	2CK-Z53	3CK-Z53	2
49	Draw bolt head	2CK-Z54	3CK-Z54	1
50	Draw-in-bolt	2CK-Z55	3CK-Z55	1